

---

## Engineering Engine/Airframe Integration for Fully Reusable Space Transportation Systems

P.W.Sacher  
Aerospace Consulting  
82024 Taufkirchen  
e-Mail: [petersacher@kabelmail.de](mailto:petersacher@kabelmail.de)

### **ABSTRACT**

*In the late 80ties and 90ties many programs were initiated in US, Russia, Japan and European countries for future space transportation systems, using airbreathing combined cycle propulsion systems. This was believed to be the Key to "system fully (or at least) partial reusability". The integration of such an engine with the airframe has been identified as the most difficult challenge for the engineering design approach.*

*The major technological requirements (e.g. "thrust minus drag" assessment) for optimum engine/airframe integration for flight vehicles using airbreathing propulsion are outlined. The major features of the internal flow-path through the airframe will be discussed specifically for the potential choice of air-intake/forebody and nozzle/afterbody design. Severe limitations of existing ground test facilities and reliable computational methods for technology verification and validation led in most studies to various proposals for flight testing. Due to the enormous high cost for technology development most trends show therefore more air-launched "simple flying testbeds" for propulsion systems demonstration rather than the classical "Experimental (X-) Aircraft" approach*

## 1.0 THE APPROACH OF THE GERMAN HYPERSONICS TECHNOLOGY PROGRAM (1988-1995)

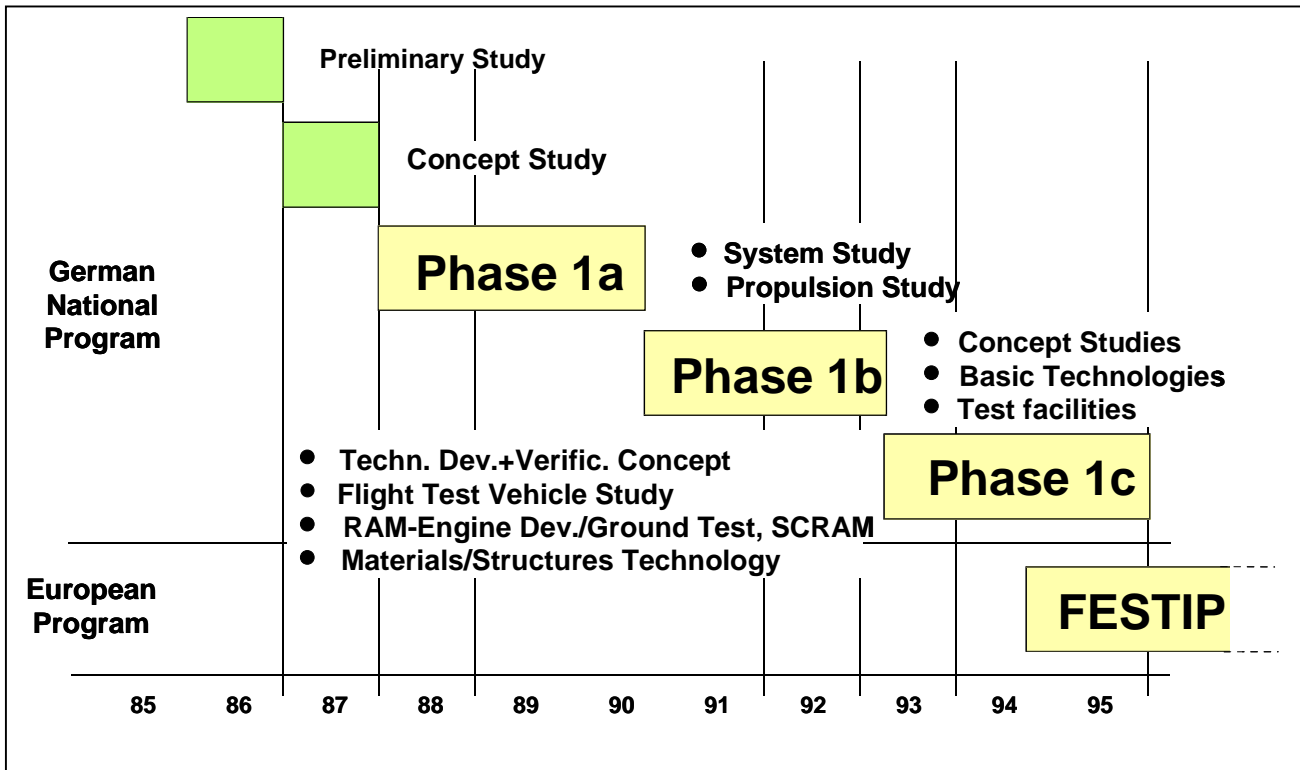
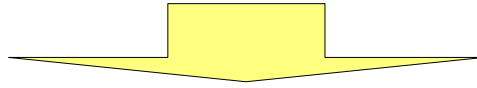

Fig. 01 SÄNGER/HTP: Schedule of the German Hypersonics Activities

In Germany efforts dedicated to these Key-Technologies were initiated during 1987-1995. They were undertaken by international cooperation within the **German Hypersonics Technology Program**. After having performed extensive System Concept Study work the decision was made to select a TSTO concept ("**SÄNGER**") as **Leading Reference Concept** for the development of the above listed "Key-Technologies" in three major time frames. At the end, mainly to shortcomings of the national budget, the program was transferred as a starting point to an ESA initiated international European program named **FESTIP** (Future European Space Transportation Investigations Program).

## 2.0 "THE KEY-PROBLEM"

The use of Airbreathing Propulsion Depends  
on its Capability to Accelerate the Flight Vehicle



**Thrust - Drag > 0**

Requires :

- Engine Thrust Enhancement
- Minimization of Engine/Airframe Integration Losses
- Aerodynamic Drag Reduction (Drag Prediction Accuracy ?)



**In-Flight-Demonstration of Successful Engine/Airframe Integration**

**Fig. 02 "Key-Technology No. 1" for A/B Engines: Engine/Airframe Integration**

The most important problem for the integration of an airbreathing engine with an airframe designed for horizontal take-off and capable for flight up to supersonic/hypersonic speed is a sufficient large positive overall thrust minus drag balance for the acceleration of the vehicle. This requires a maximum of engine thrust performance, a minimum of engine/airframe integration losses and the vehicle aerodynamic drag reduction with high prediction accuracy. This requires **validated numerical computational tools** and therefore experimental Facilities for the **simulation of the flight environment on ground**. Both requirements are not easy to achieve even in present time. Therefore the proof of successful engine/airframe integration has led to many proposals for in-flight demonstrator concepts.

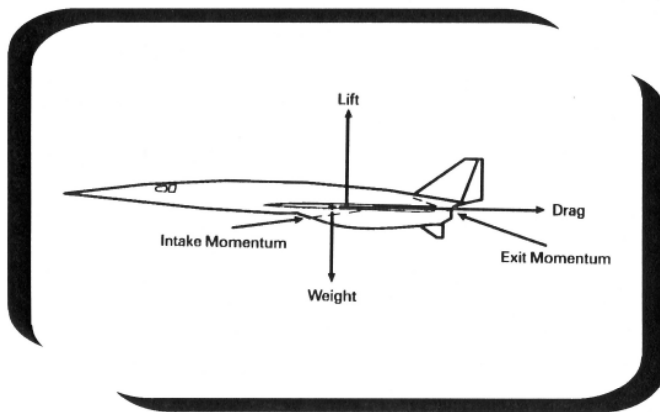

- Very high forces at engine-components
- Net-thrust: small difference of near equally high figures
- High sensitivity with reference to
  - Nozzle-aft-body-integration
  - Losses due to intake-installation
  - Realgas effects
- Impact on balance of pitching-moment for total system

PROBLEMS → Effects of engine-installation must be evaluated carefully  
GUIDELINE → Nothing to be neglected to maximize thrust-drag  
THEREFORE → Propulsion system and airframe to be optimized together

Fig. 03 Aerodynamics of Engine/Airframe Integration

The next viewgraph shows schematically the major aerodynamic forces acting on an aircraft with an integrated airbreathing engine. There are very high forces at all engine components and the resulting net-thrust to accelerate the vehicle against the aerodynamic drag is a small difference of nearly equally high numbers. This becomes specifically true at transonic speeds (e.g. "show-killer" for the NASP). There is a high sensitivity with regard to nozzle-aft-body-integration, losses due to the intake-installation and the real gas effects at hypersonic speeds beyond Mach 5. The impact of forces related to the engine on the pitching moment of the total vehicle is important (e.g. trim-losses). The conclusion is that the **propulsion system and the airframe have to be optimized together**.

### 3.0 VEHICLE CONFIGURATIONAL ASPECTS)

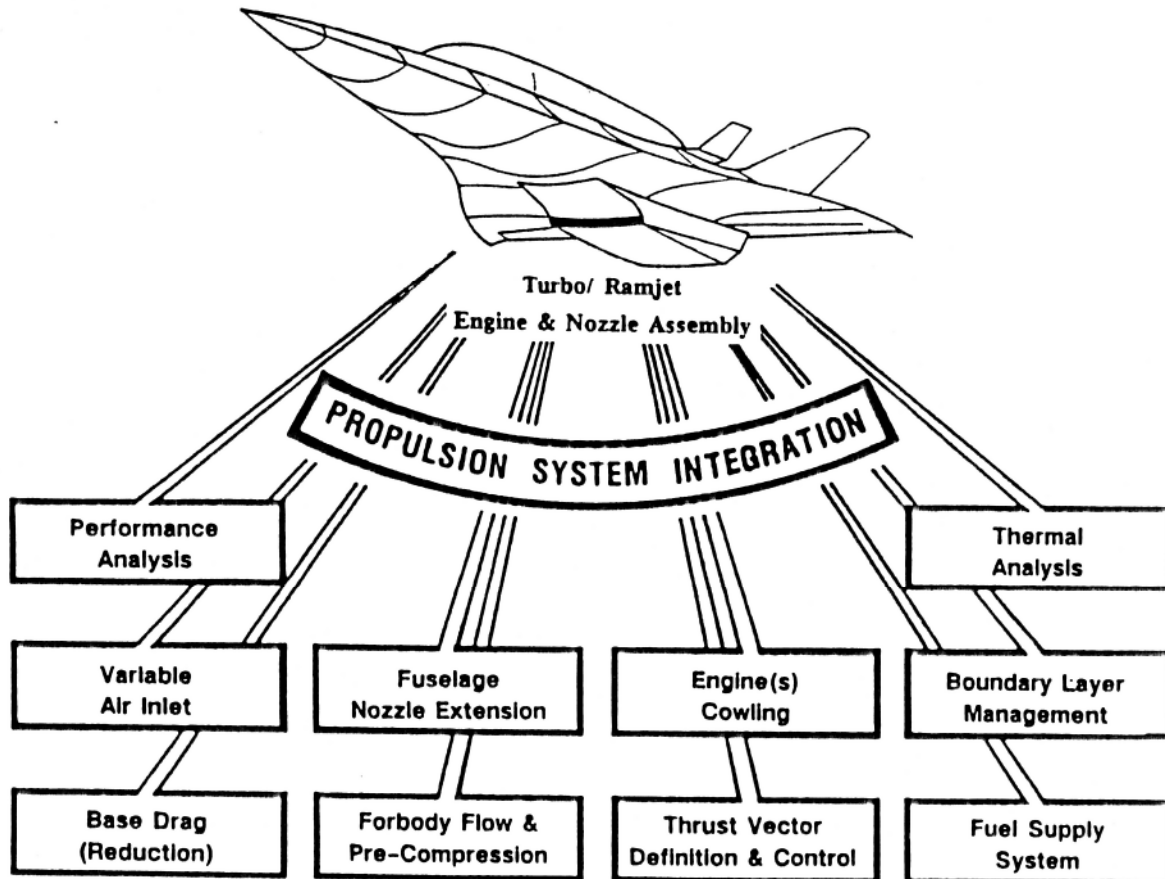

**Fig. 04 Tasks for Engine/Airframe Integration of a Turbo-Ramjet Propulsion Concept**

The engineering tasks for the optimum engine/airframe integration will be briefly discussed at an example of a turbo-ramjet propulsion engine concept. The reasons for this choice of engine concept will be outlined later.

**First**, on the engine side, the variable air inlet, the fuselage nozzle extension, the engine cowling and the boundary layer management are the most important engineering tasks.

**Second**, on the airframe side, base drag (reduction), forebody flow and pre-compression, thrust vector definition and control and the fuel supply system have to be investigated and

**Third**, an overall resulting performance and thermal analysis of the overall system has to be performed.

This leads to several mostly iterative loops ("Trade-Offs") and hopefully finally to a converged system concept fulfilling the design mission requirements.

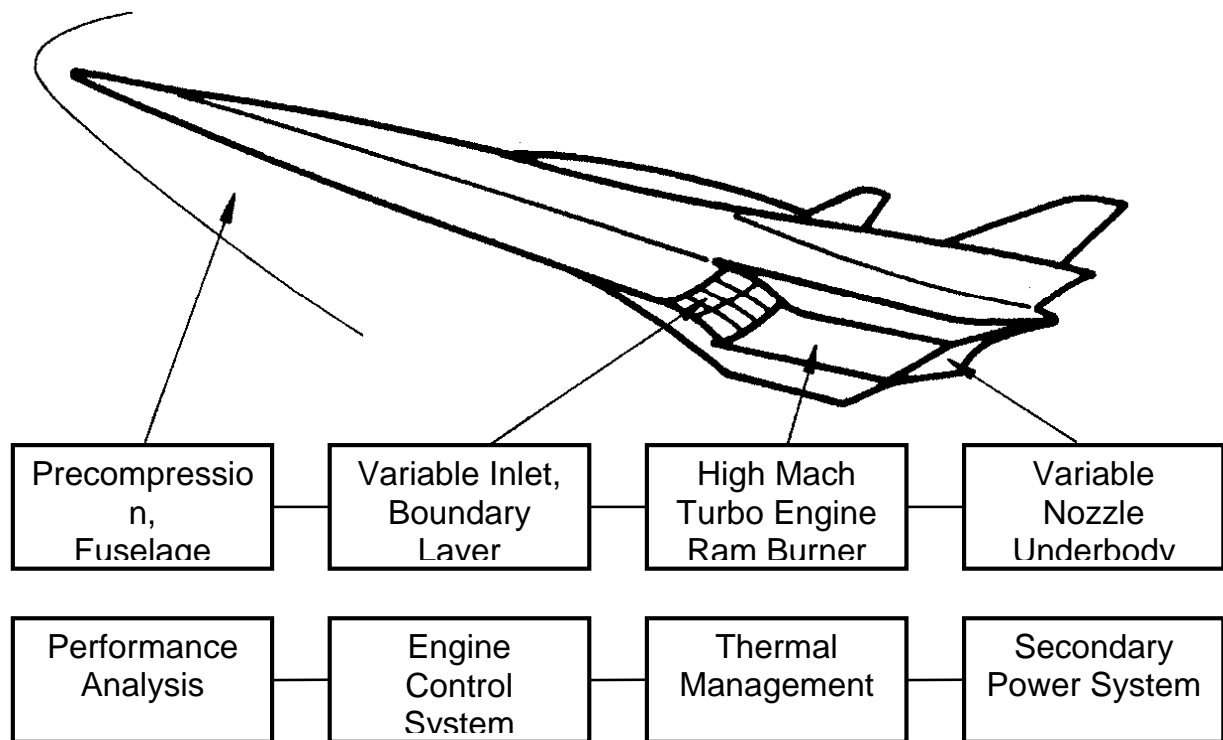

**Fig. Nr. 05 Engine Airframe Integration Issues**

This slide shows the impact of integrating an airbreathing engine on the lower fuselage of a typical configuration designed for high speed. The forebody shape is used as a precompression ramp of the engine intake and the afterbody is used as an additional 2D expansion ramp.

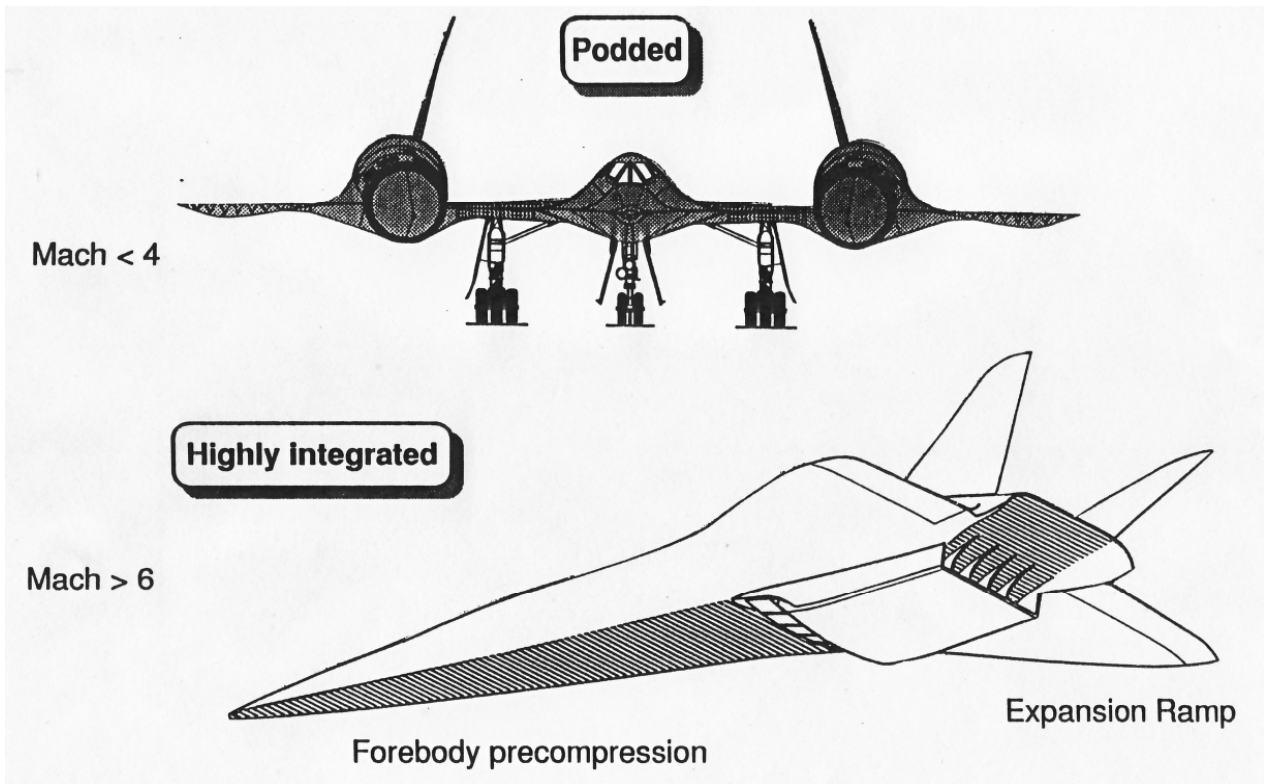

**Fig. 06 Engine/Airframe: Examples of the Choice of Systems Integration Concept**

An alternative to the highly integrated engine on the lower side of an aircraft would have been the more "conventional" nacelle Integration concept of an airbreathing engine but with nacelles integrated in the wing structure not carried by pylons below or above of the wing. This has been already demonstrated by the famous SR-71.

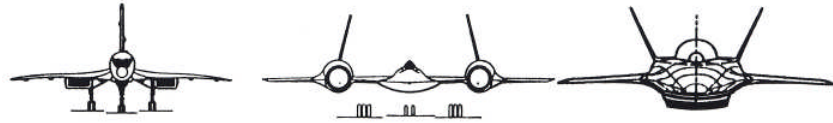

	Concorde Mach 2 under Wing Nozzles	SR 71 Mach 3.5 Integrated in Wing	SÄNGER Mach 6.8 Integrated in Body
Mutual Interference	small	very small	very important
Precompression	not essential	none	high
Afterbody Expansion	none	none	high
Drag due to Prop. System	small	small	small
Infl. on Pitching Moment	small	none	high
Yawing Moment	existent	very important	small

**Fig. 07 Air-Breathing Propulsion System Integration for Different Types of Aircraft**

A compilation of the major characteristics of alternative integration types is given by comparing the most important Pro's and Con's in this table. The Concorde as well as the SR-71 are both restricted to relative low supersonic Mach numbers. This is mainly due to the missing precompression effect of the aircraft fuselage afterbody nozzle expansion ramp. But on the other hand the asymmetric afterbody expansion ramp produces a high influence on the pitching moment of the whole vehicle which has to be controlled. This leads in most cases to additional trim-drag and will be discussed later in detail.



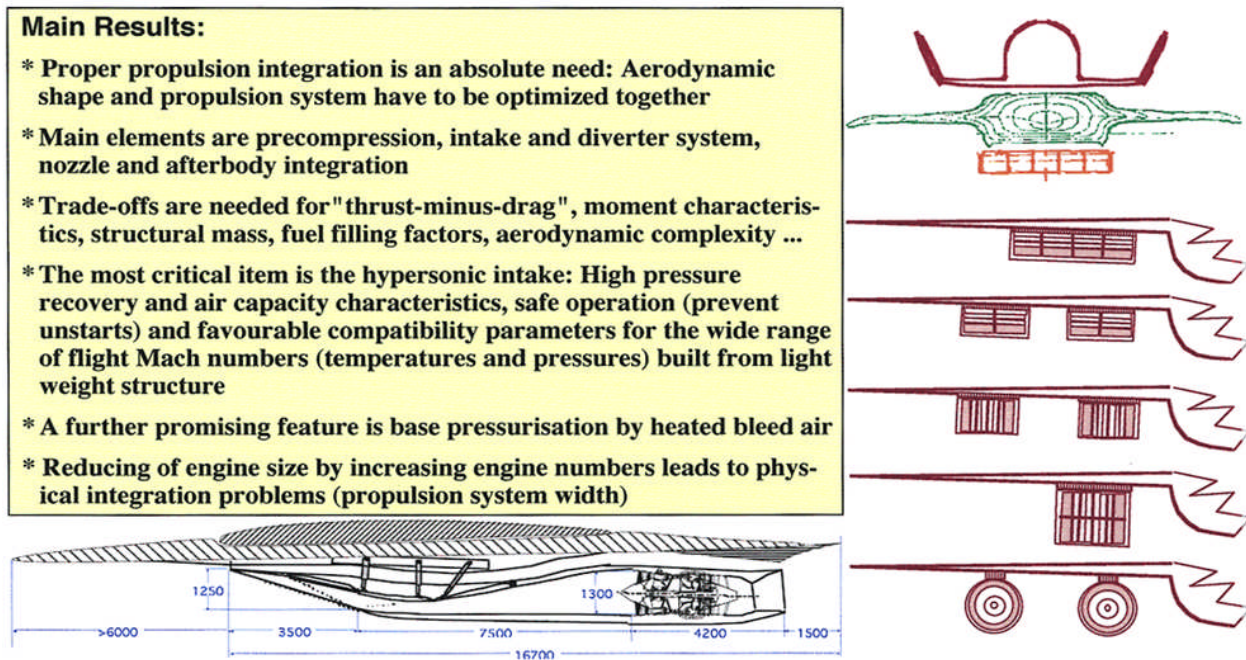
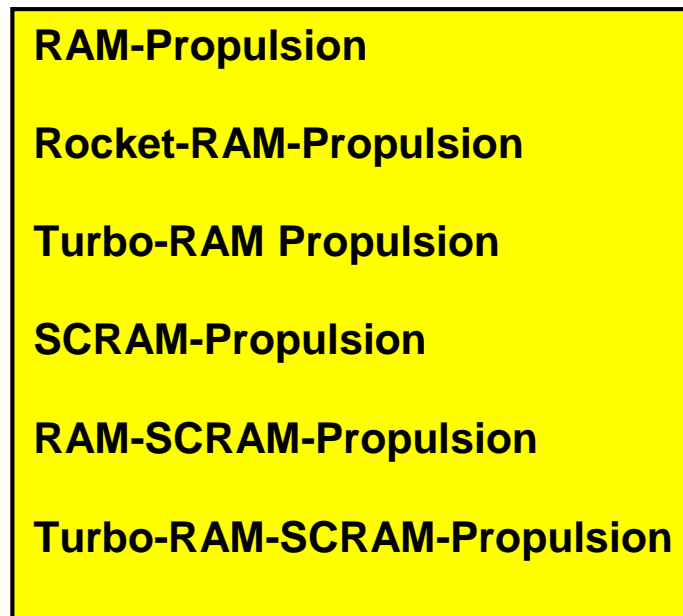

**Fig. 08 Integration Aspects of Airbreathing Engines in Launchers**

A summary of the integration aspects of airbreathing engines in hypersonic vehicles (= launchers) concludes this section:

- Aerodynamic shape and propulsion system have to be **optimized together**
- **Main elements** of the airbreathing engine are precompression, intake and diverter system, nozzle and afterbody integration
- **Trade-offs** are needed for "thrust-minus-drag", moment characteristics, structural mass, fuel filling factors, aerodynamic complexity and etc.
- The most critical item is the **hypersonic intake**: high pressure recovery and air capacity characteristics, safe operation (prevention of intake un-start), and favourable compatibility parameters for the wide range of flight Mach numbers (temperatures and pressures) built from light weight structure
- A further promising feature is **base pressurisation** by heated bleed air ("external burning")
- Reduction of **engine size** by increasing engine numbers leads to physical integration problems (see SÄNGER)

#### 4.0 ENGINE CYCLE



**Fig. 09 Alternative Air-Breathing Propulsion System Concepts under Consideration for Hypersonic Speed**

At the beginning of the 90ties RAM and Rocket/RAM Propulsion was already applied to Missiles. Turbo-RAM had been tested and flown in Russia and the US for military aircraft. SCRAM and RAM-SCRAM were investigated in simple experimental windtunnel models within the German Hypersonics Technology Program and in the French PREPHA. Turbo-RAM-SCRAM seems to be the next logical step. But before this step was taken a comprehensive Trade-Off was undertaken within the German TSTO SÄNGER program as the next slide shows.

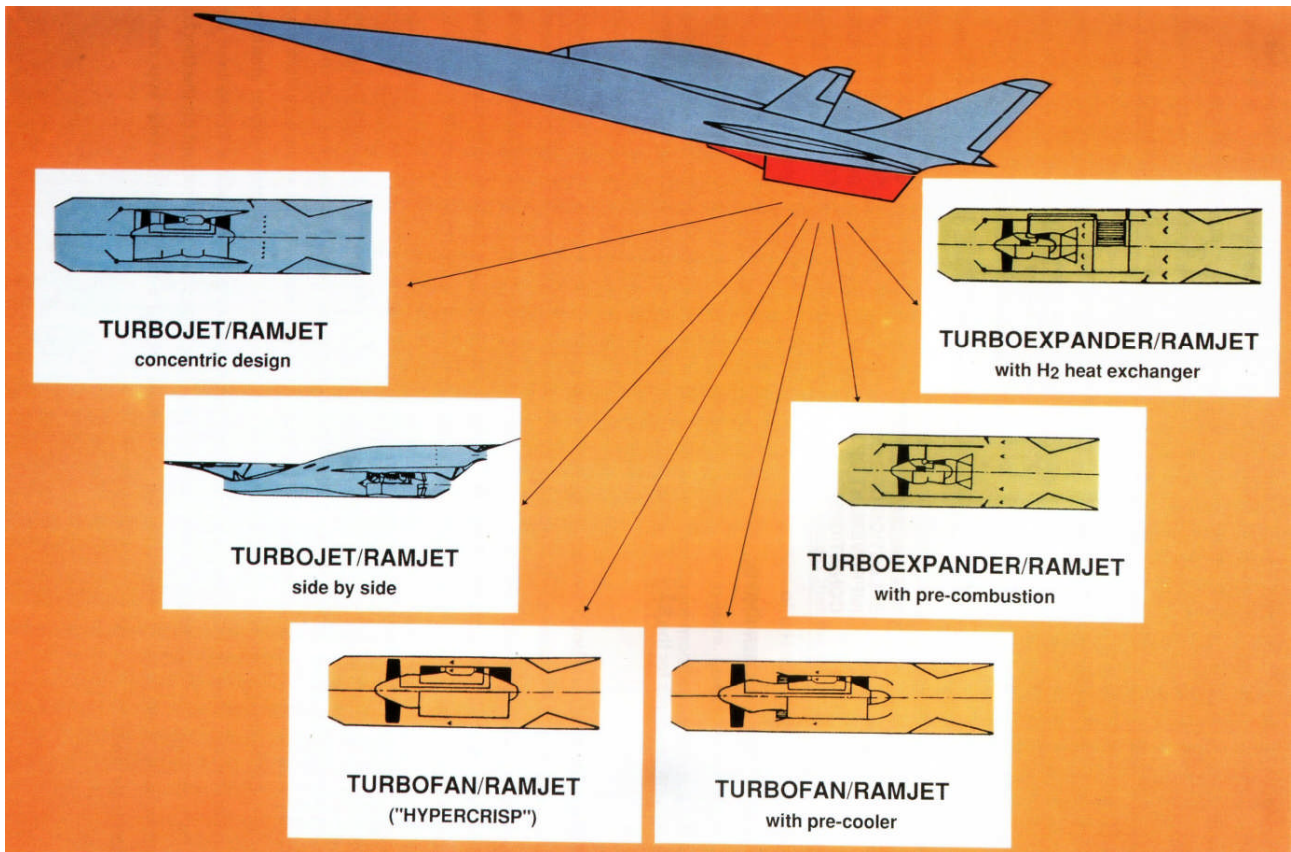

**Fig. 10 Airbreathing Propulsion Concepts Investigated During the TSTO SÄNGER Program**

For the first stage of the SÄNGER concept the Turbojet/Ramjet was chosen with a concentric internal Flow-path. Mainly due to its volumetric design the parallel arrangement of the Turbo and RAM mode was not investigated any more. The Turbo-expander/Ramjet either with Heat-exchanger or with Pre-combustion was considered to be out of practical reach and the Turbofan/Ramjet concept was due to the high entry temperature into the compressor not able to reach Mach around 6, the separation Mach number of the SÄNGER stages.

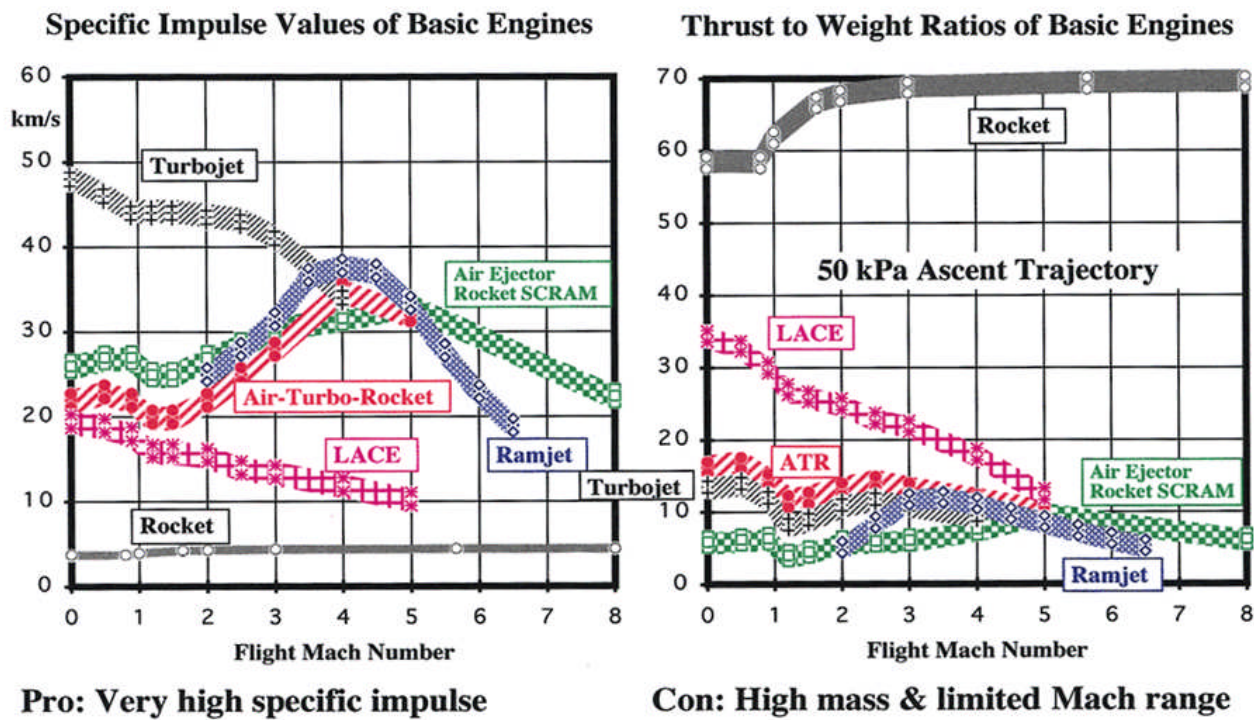
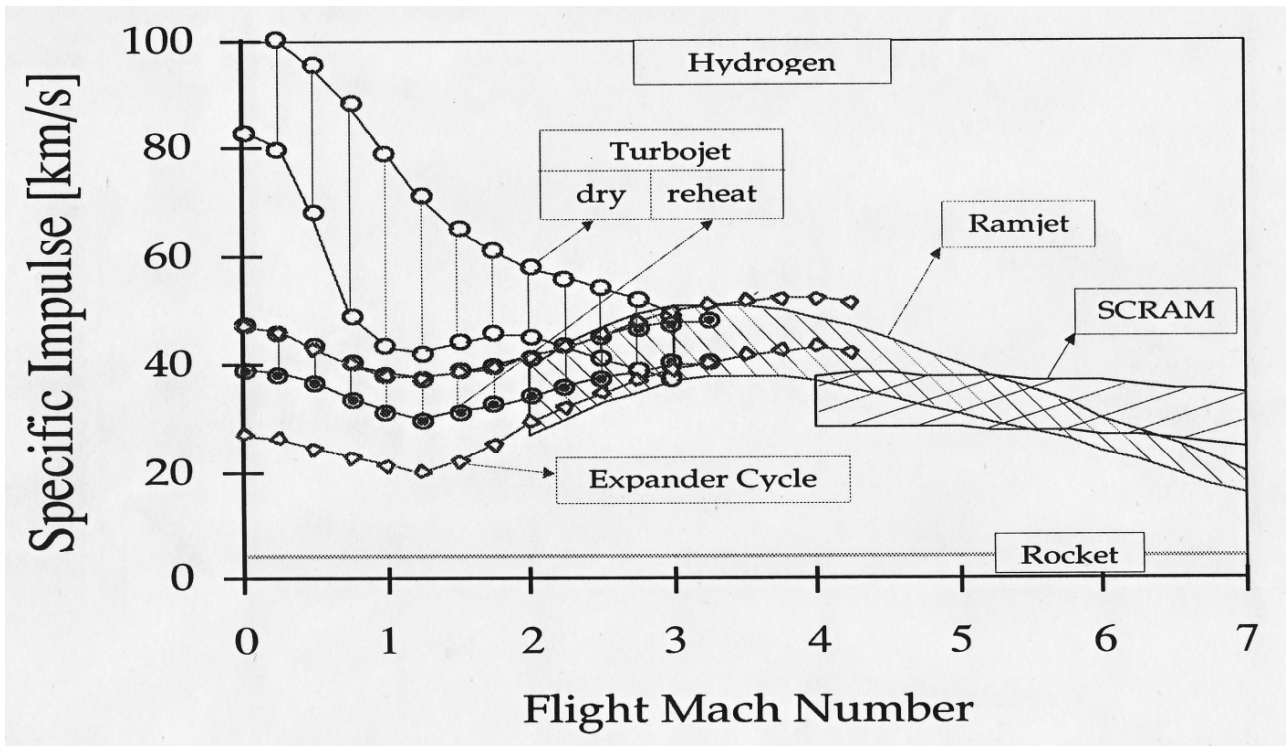

Fig. 11 Performance Rationales of Airbreathing Engines

In order to understand the rationale for selecting the propulsion system concept for SÄNGER first stage is important to compare the major performance characteristics of the engine cycle types which were under consideration as potential candidates. The left side of the slide shows the specific impulse values of the different engine types and on the right side the thrust to weight ratios. Included in these charts are the values for a rocket engine. The assessment of the individual "Pros" and "Cons" in addition to availability and cost needed for technology development led finally to the selection of the turbojet/ramjet combined cycle engine.



**Fig. 12 Alternative Fundamental Propulsion System Concepts and Combinations**

In this slide the typical values for specific impulse of three basic engine types: turbojets, ramjets and rockets including variants, turbo expander cycle engine and scramjets are given within some bandwidth. For the turbo engine there are shown two operational modes: with and without afterburner (reheat and dry). Only the rocket engine with its very low specific impulse can cover the whole Mach number range required for the SÄNGER first stage. This has led finally to the selection of a combination of two basic engine types, the turbo-ramjet combined with the ramjet.

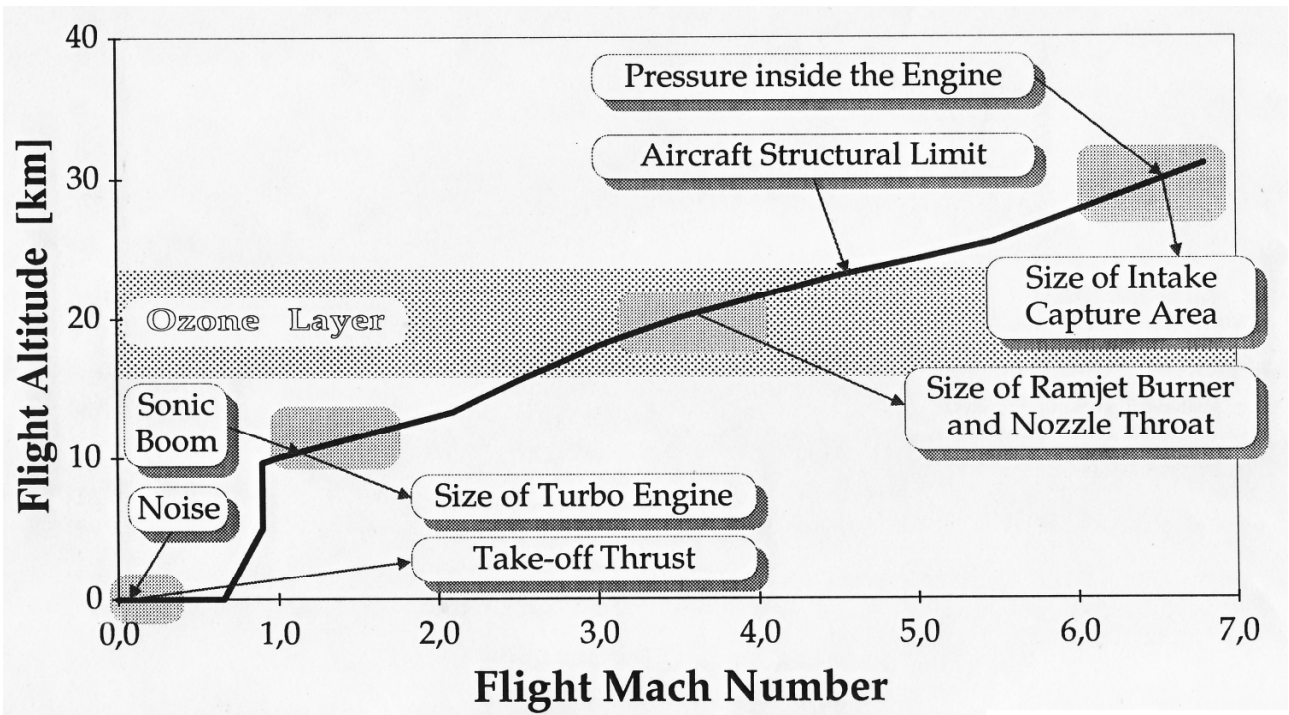

Fig. 13 Engine/Airframe Integration: Most Critical Design Limitations

The engine for a high speed transport vehicle has to be designed to meet the most critical design limitations given by the flight trajectory especially for the ascent part and the mission constraints and integration limitations as the figure shows. The size of the Turbo-engine is first of all defined by the take-off thrust requirement. The flight at higher Mach number (after transition from the turbo-to-ram operation mode) along the trajectory is performed at constant dynamic pressure according to the limitations of the airframe structure. This defines the size of the ramjet burner and the nozzle throat. Remarkable to note: The size of the intake capture area is designed for the maximum Mach number at high altitude and the pressure inside the engine. Although the intake has variable intake ramps this leads in many cases to spill-drag due to by-passing parts of the airflow at low speeds ("Intake Design Miss-match").

## 5.0 FOREBODY DESIGN

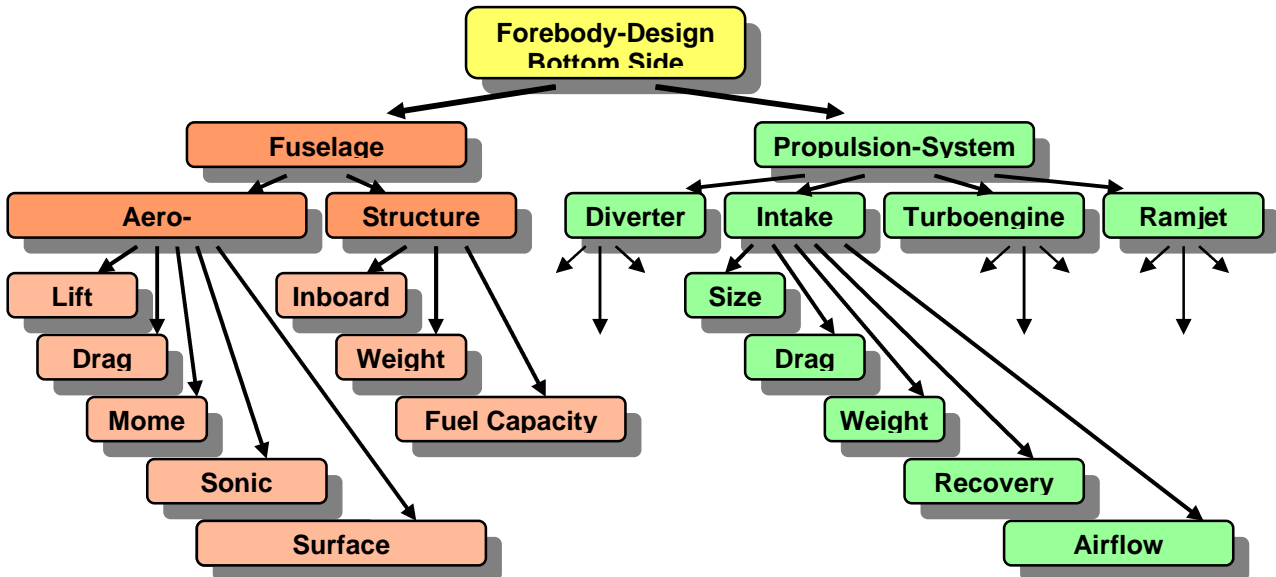
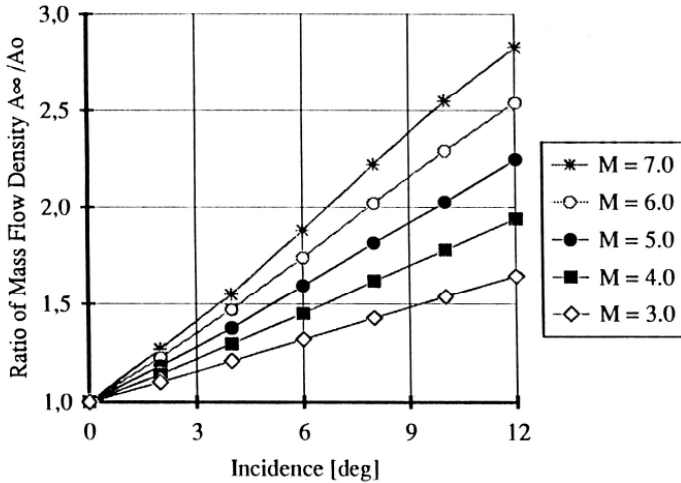
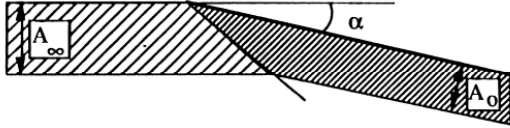

Fig. 14 Influence Paths of Forebody Design

The design of the forebody is responsible not only for lift, drag and stability. It also influences the engine design and performance. This rather complex interacting problem is shown schematically in this figure. The shape of the whole bottom side of the fuselage has to be designed to achieve a maximum precompression of the undisturbed airflow in order to enlarge the amount of air captured by the intake. One additional problem exists for the forebody design: The boundary layer of the forebody has to be separated before entering the intake by a diverter. In case of the SÄNGER design the boundary layer air is led through the fuselage by a separate duct and then is blown in the nozzle external part.

Flat Plate with Incidence



"Sänger"-Type Forebody

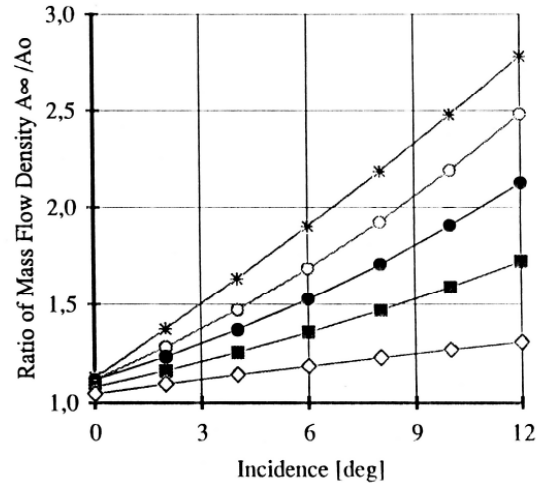
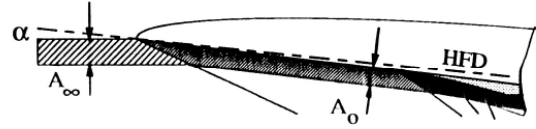
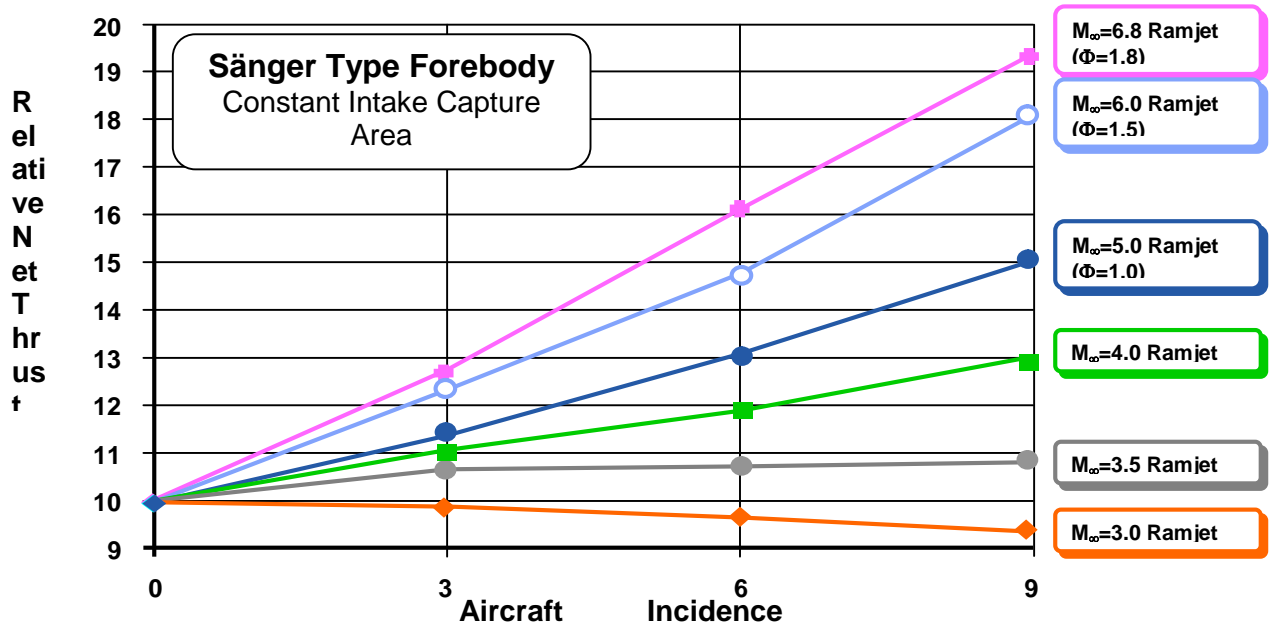

Fig. 15 Engine/Airframe Systems Integration: Pre-compression of Forebody Shape at the Lower Side

The effect of forebody precompression is explained in this figure by comparing the mass flow density "stream tube area ratio"  $A_\infty/A_0$  for a flat plate and the SÄNGER type forebody. In both cases this ratio is strongly increased with freestream Mach number and AoA.





**Fig. 16 Precompression Effect on Net Thrust of Turbo-Ramjet Engines**

The next figures will show examples for the comprehensive design work which has been undertaken within the Hypersonics Technology Program. For two experimental flying test-beds (HYTEX and RADUGA) to demonstrate the impact of forebody precompression performance at hypersonic flight conditions alternative forebody shapes have been investigated in detail using numerical methods. Fig. 17 shows the geometry of the forebody shapes. Fig. 18 and 19 presents the results.

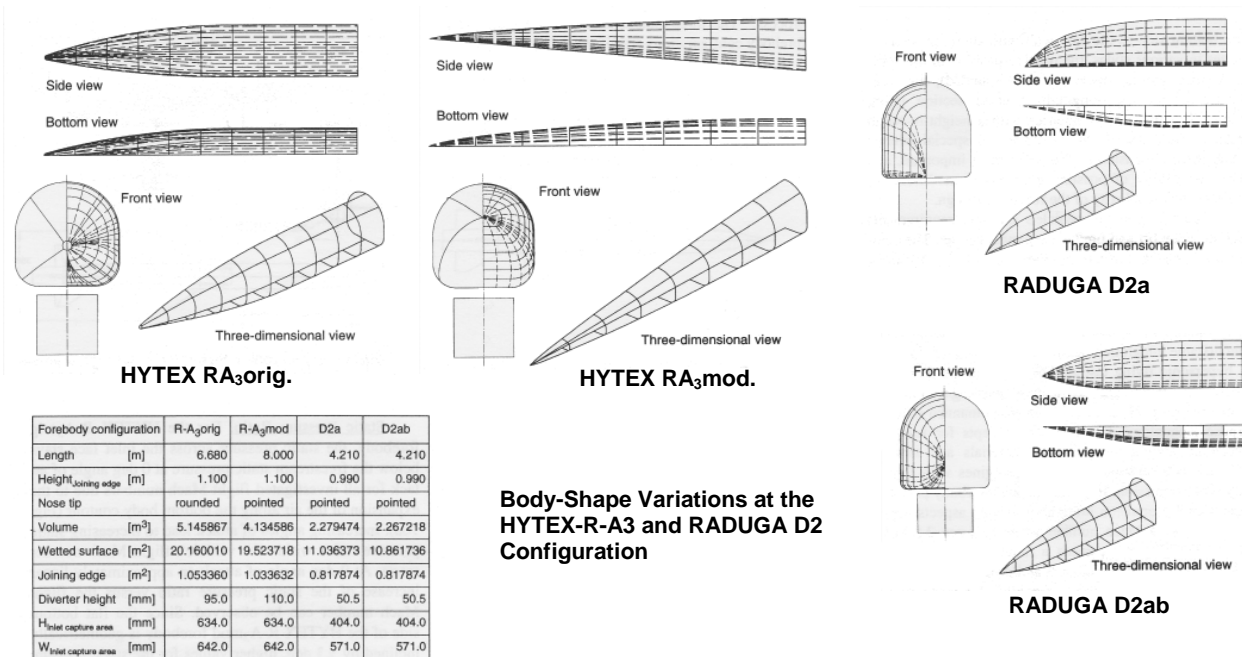

Ref.: Berens, Bissinger, AIAA-98-1574, Norfolk

**Fig. 17 The Impact of Forebody Precompression Performance at Hypersonic Flight Conditions**

The next figures will show examples for the comprehensive design work which has been undertaken within the Hypersonics Technology Program. For two experimental flying test-beds (HYTEX and RADUGA) to demonstrate the impact of forebody precompression performance at hypersonic flight conditions alternative forebody shapes have been investigated in detail using numerical methods. Fig. 17 shows the geometry of the forebody shapes. Fig. 18 and 19 presents the results.

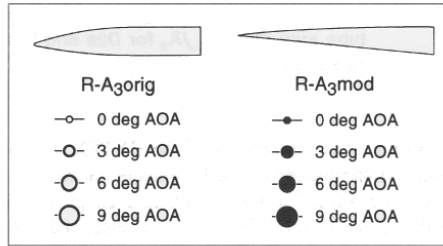

Static Pressure Ratios  $p_{so}/p_{soo}$

Intake entry Machnumbers  $Ma_o$

Total Pressure Ratios  $p_{to}/p_{too}$

Stream Tube Area Ratios  $A_w/A_o$

For the HYTEX R-A<sub>3</sub>orig. and R-A<sub>3</sub>mod. Vehicle forebodies in Front of the Inlet Location

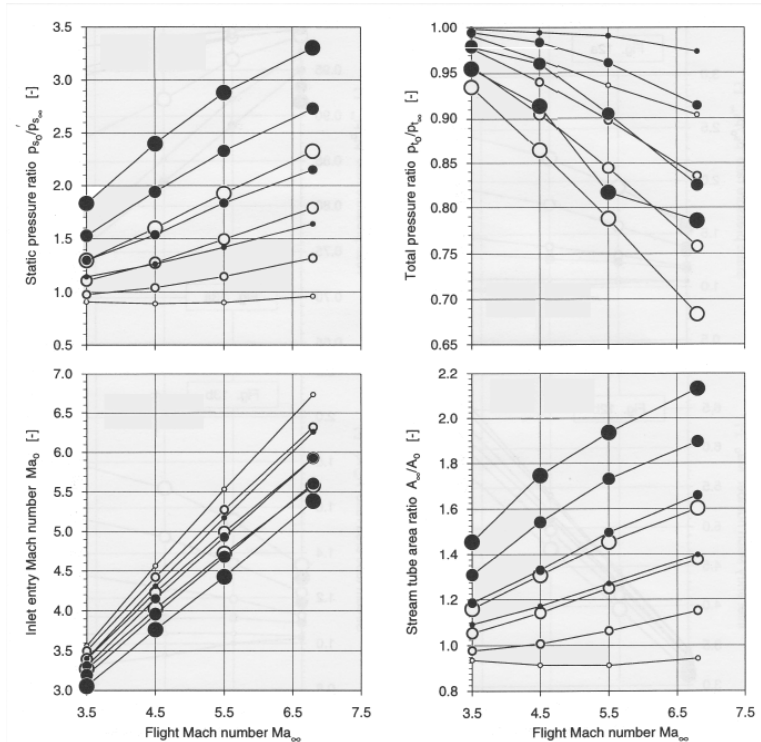

Ref.: Berens, Bissinger, AIAA-98-

Fig. 18 & 19 The Impact of Forebody Precompression Performance at Hypersonic Flight Conditions, HYTEX (above), RADUGA (below)

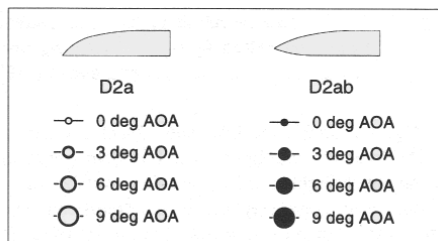

Static Pressure Ratios  $p_{so}/p_{soo}$

Intake entry Machnumbers  $Ma_o$

Total Pressure Ratios  $p_{to}/p_{too}$

Stream Tube Area Ratios  $A_w/A_o$

For the Raduga D2a and D2ab Vehicle forebodies in Front of the Inlet Location

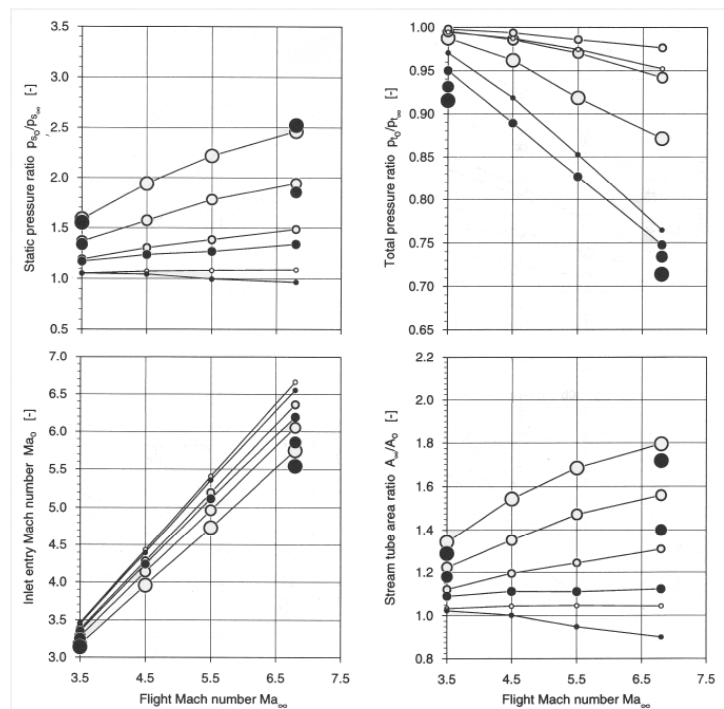

Ref.: Berens, Bissinger, AIAA-98-

## 6.0 INTAKE DESIGN

### Objectives:

- **Assessment of the impact of true temperature corresponding to flight Mach numbers up to 7 (requires "free-jet" testing)**
- **Data acquisition during test, verification and validation of design tools**
- **Impact of materials and structures on intake design and manufacturing for high temperature testing intakes with variable geometry parts (e.g. ramps with cooling, sealing, pressurizing, ...)**

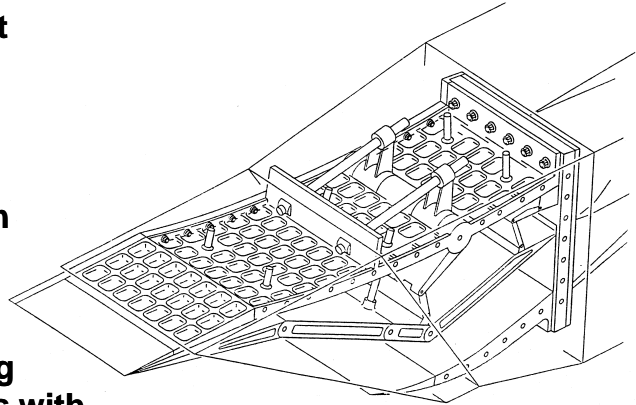
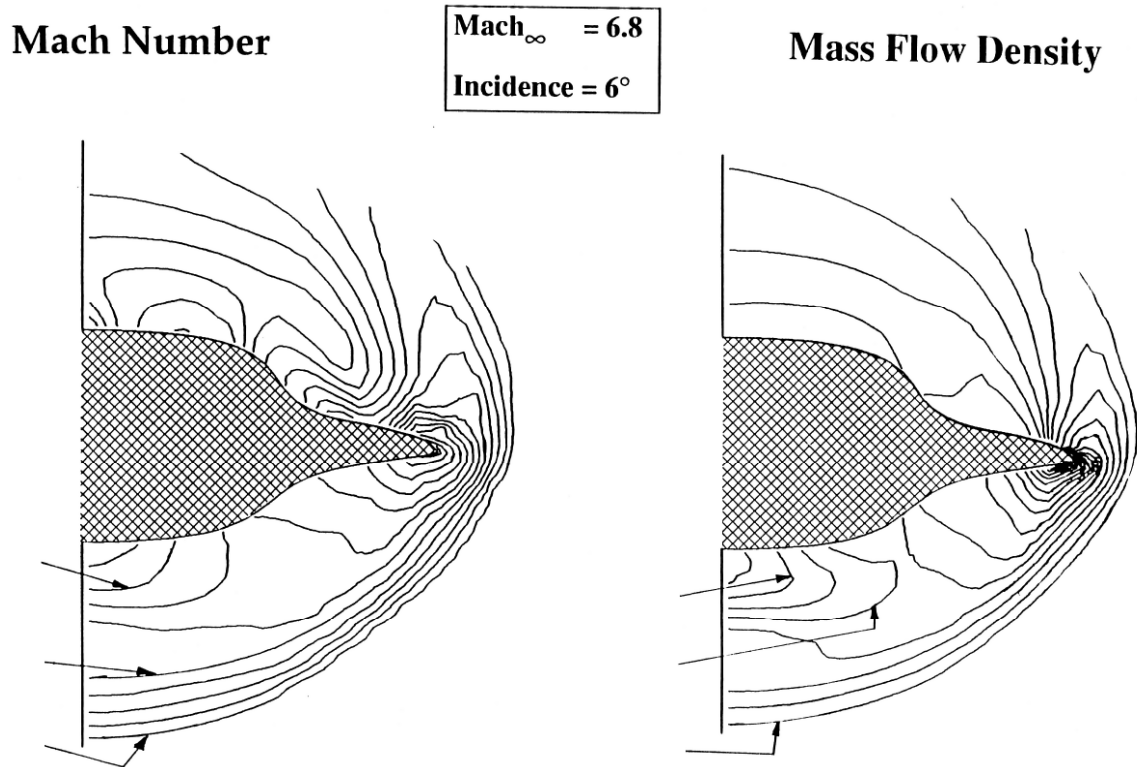

Fig. 20 "Key Technologies": Engine/Airframe Integration wrt Intake Design

Shows the Intake design to be built and flown on the hypersonic test-vehicle HYTEX RA-3. On this vehicle a possible engine configuration would have a combustion chamber of 50 cm and a total length of the complete engines of about 8m. Two windtunnel models with 2-D geometry with 1:10 scale had been designed and two of them were tested up to hypersonic speed in the German windtunnel TMK at the DLR in Cologne.

The **first** generic model with a cross flow section of 10cm x 10 cm, fixed ramps and movable side walls was tested at "cold" free-stream numbers of  $M_\infty = 2.9$  and 5. Based on this experience a **second** generic model was built with the same scale, but with boundary layer (from a flat plate simulating a forebody) without diverter duct and four movable ramps but again only in "cold" free-stream numbers of  $M_\infty = 4.5, 5.0$  and 5.2.

The next logical **third** step was then in 1994 the design of a full scale intake to complete the SÄNGER propulsion system. The combustion chamber with nozzle was already tested in the MBB connected pipe test facility in Ottobrunn with a 30 cm diameter scale. It was planned to integrate all three engine components in the large 50cm diameter scale in 1995 and to test the complete engine in a large windtunnel test facility up to Mach 7. The choice was made to use for this test the APTU test facility of AEDC, Tullahoma in the United States.



**Fig. 21 CFD for Prediction of Machnumber and Massflow density at the Cross-Section where the Intake Entry Plane will be Located**

As a result of the design of the forebody the flow properties at the cross section of the airframe body at the location of the intake caption area (A0) have been calculated for  $Mach_{\infty}$  6.8 (stage separation) and 60 AoA using CFD Euler codes. The lines are isolines for local Mach number (left) and mass flow density (right).

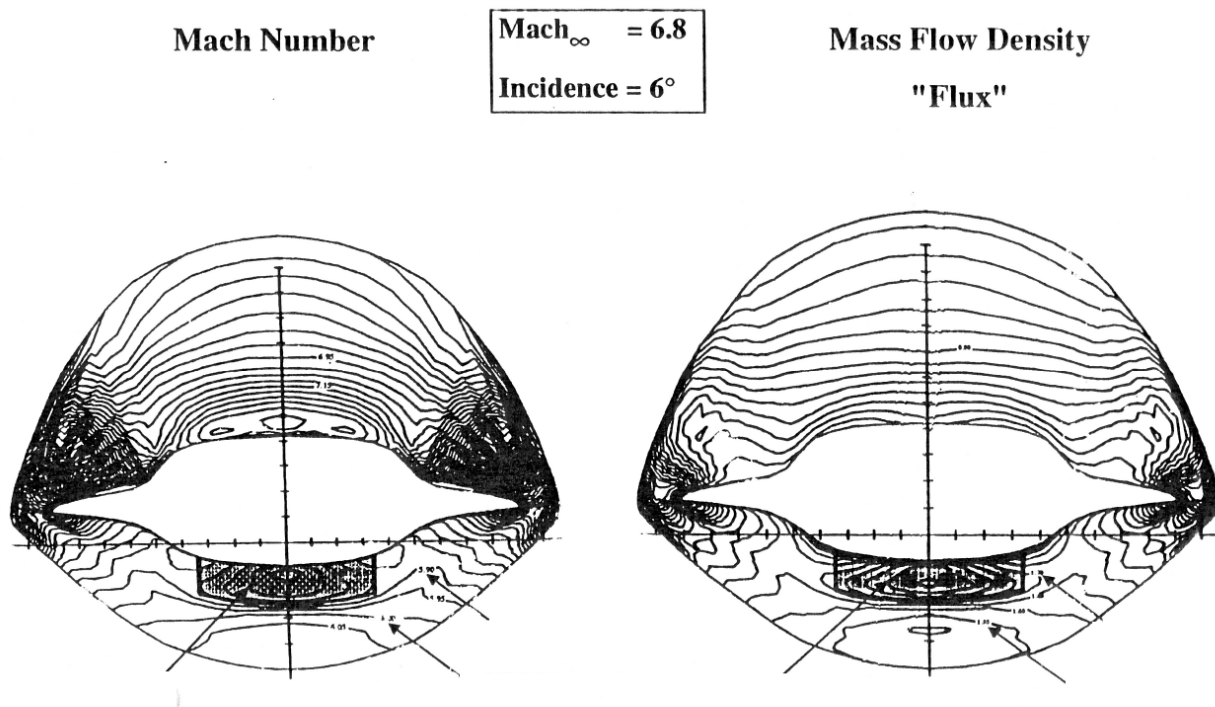

**Fig. 22** CFD for Prediction of Machnumber and Massflow density at the Cross-Section at the Installed Intake Entry Plane

In Fig. 22 the isolines within the intake capture area is shown. From this picture the non-uniformity of local Mach number and local flux can be assessed within the intake capture area. The important result of the design of the forebody has already shown and discussed in Fig. 16.

## 7.0 NOZZLE DESIGN

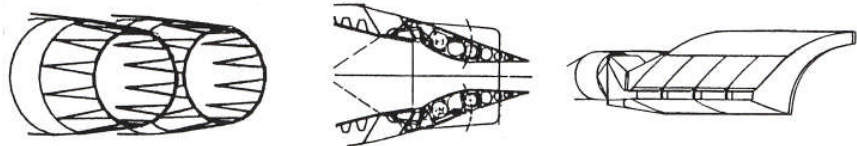



	Axisymmetric C-D	2D-CD	Single Expansion Ramp Nozzle (SERN)
Variable Throat Area	questionable	good	good
Performance	unsatisfactory	good	good
Weight	bad	difficult	good
Integrability	medium	high	favorable
Contrib. to Pitch Moment	none	none	high
Cooling	high losses	difficult	feasible
Vectorization	none	possible	limited

**Fig. 23 Characteristic Features Different Types of Nozzle Concepts**

This brings us to the second most important engine/airframe integration design problem: the choice of an appropriate nozzle type and its "mating" with the aircraft afterbody. For a hypersonic flight vehicle there exists an extreme wide range of nozzle pressure ratios from about 2 up to 500 and therefore resulting nozzle throat and exit areas varying from 1 to 6 between minimum and maximum size. This Figure shows the three well known types of Nozzles:

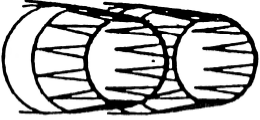
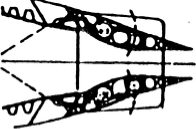
- axisymmetric convergent-divergent
- two dimensional convergent-divergent and
- Single Expansion Ramp Nozzle (SERN)

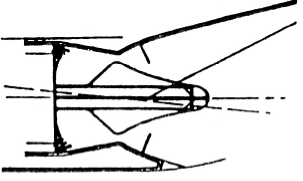
Axisymmetric Flap C-D	2D - CD	2D - SERN	Plug
			
<ul style="list-style-type: none"> <li>➤ Conventional design</li> </ul>	<ul style="list-style-type: none"> <li>➤ High flexibility, performance</li> <li>➤ Thrust vectoring</li> </ul>	<ul style="list-style-type: none"> <li>➤ High flexibility, performance</li> <li>➤ Limited vectoring</li> </ul>	<ul style="list-style-type: none"> <li>➤ Conventional structure and cooling</li> <li>➤ Light weight</li> </ul>
<ul style="list-style-type: none"> <li>➤ Limited area ratios</li> <li>➤ Low performance at high speeds</li> <li>➤ Leakage problems</li> <li>➤ Cooling problems</li> </ul>	<ul style="list-style-type: none"> <li>➤ Extreme high weight</li> <li>➤ Leakage</li> <li>➤ Cooling</li> </ul>	<ul style="list-style-type: none"> <li>➤ Thrust angle variations</li> <li>➤ Leakage</li> <li>➤ Cooling</li> </ul>	<ul style="list-style-type: none"> <li>➤ Active thrust vectoring difficult</li> <li>➤ Low off-design performance</li> </ul>
Combination with fixed or movable plug	Highly sophisticated design, new materials and cooling structures		Combination with single expansion ramp
<b>Low speed off-design performance may be improved by injection of secondary air</b>			

**Fig. 24 Configurational Basic Nozzle Types under Consideration**

This chart goes a little bit more in details of the different options for selecting an optimum nozzle type. For the SERN an additional variant with a plug for SÄNGER was investigated. The plug has to be movable forward and backwards to provide a variable nozzle throat area. After having considered all pros and cons during several trade-offs the 2D SERN was selected for the SÄNGER first stage.



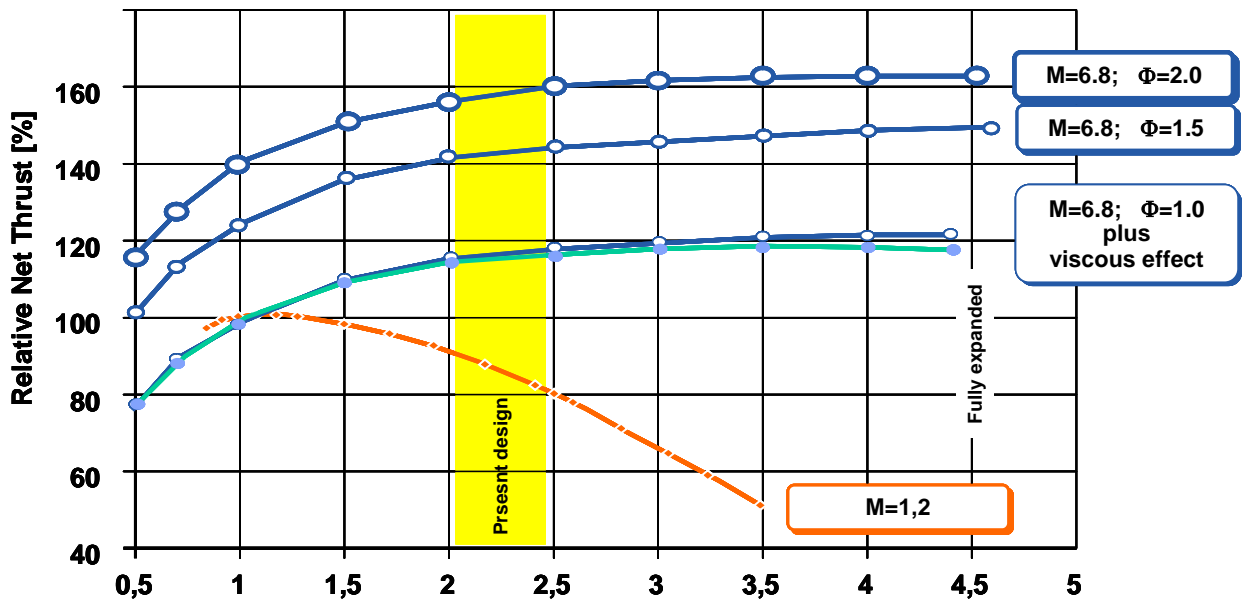

**Nozzle Exit Area Optimization is an Important, Configuration Dependent Trade-Off, Considering Internal Performance, External Drag, Thrust Vector Direction, Longitudinal Stability, Nozzle Weight & Cooling**

Ref.: O. Herrmann, AGARD Fort Worth 91, Pap. No. 32

**Fig. 25 Effect of Nozzle Expansion Exit Area on Net Thrust**

The next chart addresses the important decision on the length of the un-symmetric expansion Nozzle ("A9"). The nozzle area extension requires configurational trade-offs, the consideration of the internal nozzle performance, vehicle external drag, definition of the resulting thrust vector direction and its influence on longitudinal stability and, in addition, structural impacts e.g. weight and cooling. The figure shows the location of the final design. Plotted is the relative net thrust versus  $A_9/A_0$ .  $\Phi = 1$  (stoichiometric) is the fuel/air ratio.

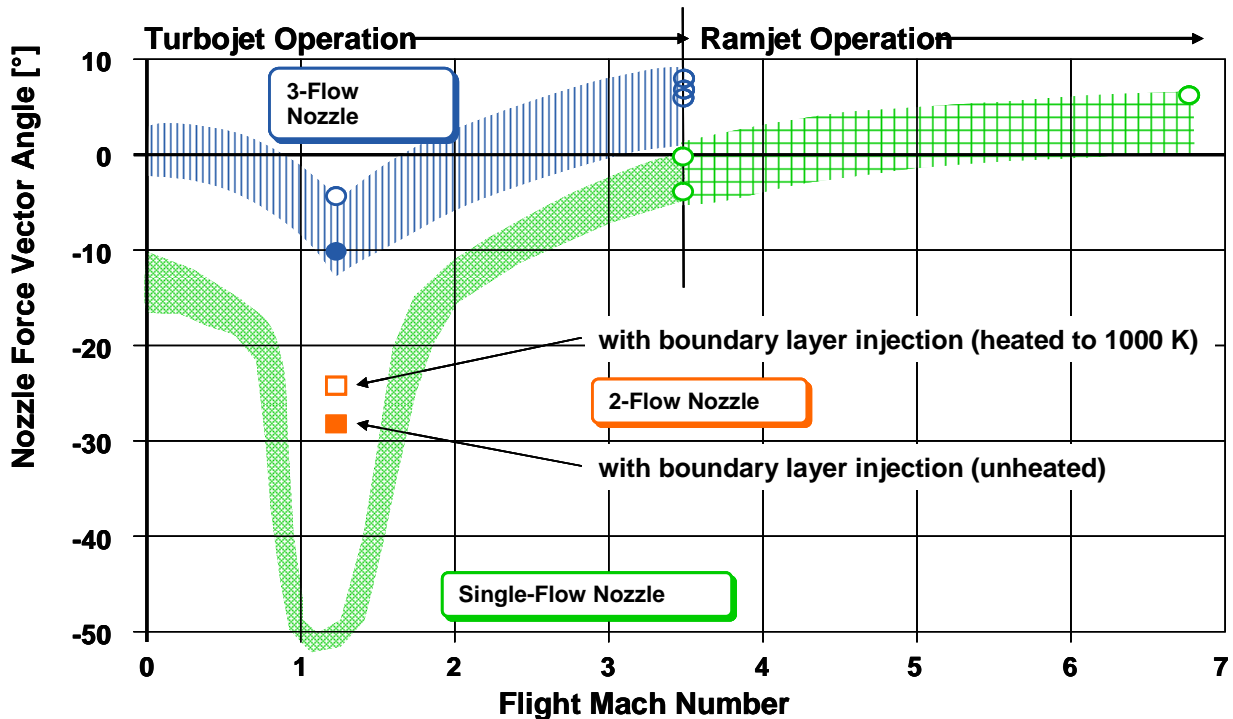





**Nozzle Design not only Effects Thrust, but Largely Trim & Stability**

Ref.: O. Herrmann, AGARD Fort Worth 91, Pap. No. 32

**Fig. 26 Euler Results for 2D-SERN Nozzles: Nozzle Force Angle with Regard to HRD**

From the previous charts (Fig. 21) we have seen that one of the biggest Problems from SERN Nozzle arrangements is its Mach-dependent generation of large negative thrust vector angles especially in the transonic speed range. With CFD Euler codes numerical investigations were undertaken to assess these nozzle force vector angles and to find appropriate means to improve this effect on longitudinal stability. The calculations were done following three different assumptions for the jet flow acting on the SERN Nozzle concept. Single flow nozzle without injection of secondary air resulting in extreme downward directed forces. In case of a Double-flow nozzle boundary layer air was injected unheated and heated. This led to a reduction of the downward vector angle by a factor of 2. In case of a tripple-flow nozzle it was assumed turbojet operation in parallel to the ramjet engine and ejection of the forebody boundary layer. This would reduce the negative thrust vector angle to less than 10 deg. But this would require a complete different arrangement of the turbo and ram engine (wrap around or over-under).

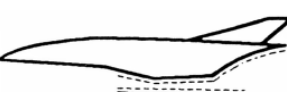
## 8.0 BOOK KEEPING

Propulsion Definition	Description	Pro	Con
	<ul style="list-style-type: none"> <li>All surfaces Wetted by</li> </ul>	<ul style="list-style-type: none"> <li>Prop Analysis Starts in Uniform Flow</li> <li>Minimum Corrections at</li> </ul>	<ul style="list-style-type: none"> <li>Aero Includes Major Lifting Surfaces</li> </ul>
	<ul style="list-style-type: none"> <li>Wetted Surfaces Aft of</li> </ul>	<ul style="list-style-type: none"> <li>Aero Includes Forebody Lifting Surface</li> <li>Minimum Corrections at</li> </ul>	<ul style="list-style-type: none"> <li>Aero Excludes Nozzle Lift &amp; Trim</li> <li>Prop Analysis Starts in</li> </ul>
	<ul style="list-style-type: none"> <li>Wetted Surfaces Aft of</li> </ul>	<ul style="list-style-type: none"> <li>Aero Includes Forebody &amp; Inlet Lifting Surfaces</li> <li>Boundary is Well Defined</li> </ul>	<ul style="list-style-type: none"> <li>Aero Excludes Nozzle Lift &amp; Trim</li> <li>Prop Analysis Starts in</li> </ul>
	<ul style="list-style-type: none"> <li>Wetted Surfaces Between</li> </ul>	<ul style="list-style-type: none"> <li>Aero Includes Forebody &amp; Inlet Lifting Surfaces</li> <li>Boundary is Well Defined</li> </ul>	<ul style="list-style-type: none"> <li>Aero Excludes Nozzle Lift &amp; Trim</li> <li>Prop Analysis Starts in</li> </ul>
	<ul style="list-style-type: none"> <li>Wetted Surfaces Aft of Engine Face and</li> </ul>	<ul style="list-style-type: none"> <li>Aero Includes Major Lifting Surfaces</li> </ul>	<ul style="list-style-type: none"> <li>Aero Excludes Nozzle Lift &amp; Trim</li> <li>Prop Analysis Starts in Complex Flow</li> </ul>

Ref.: K. Numbers, Hypersonic Propulsion System Force Accounting, AGARD 7.-10.

**Fig. 27 Book-Keeping (Force Accounting) Different Alternatives**

An assessment of the total drag of a flight vehicle without an airbreathing engine is more or less the sum of aerodynamic components e.g. viscous drag, induced drag, interference drag etc., all related to the vehicle external flow field. In case of a highly integrated airbreathing engine an internal flow-path exists which contributes additional drag components. Within an integrated design team aerodynamicists and propulsion engineers have to agree on the definition of a so-called "Book-Keeping" technique which clearly defines the area of responsibility. It is clear that these boundaries are strongly dependent on the vehicle shape and the selected engine type and geometry. The Fig. 24 shows an example for a hypersonic flight test vehicle which has been selected as a demonstrator for engine/airframe integration (SÄNGER Type).

In the **upper case** all surfaces contributing to the propulsion flow include forebody, intake including the first (or more) compression ramps, Intake cowl lip, the complete engine internal duct, the nozzle and the complete expansion ramp. So the aerodynamicist must not take care of some major lifting surfaces. The interface between external and internal flow-path becomes a function of Mach,  $\alpha$  and  $\beta$ .

In the **lower case** the propulsion responsibility starts from the engine face (after the intake) and ends at the nozzle throat. The boundary here is well defined but the propulsion analysis starts with a complex flow which has to be specified for all flight conditions along the mission trajectory. Questions: what happens with the boundary layer? Who is responsible for intake un-start?

**Thrust and drag during ascent trajectory of a two-stage-to-orbit transport system based on combined cycle turbo-ramjet propulsion system**



**Show-Killer!**  
 In many cases Net-Thrust around Mach = 1.0 (or Mach at transition from turbo-ram) is not sufficiently high (or even negative) than thrust required to accelerate the vehicle within the limits of time (available fuel)

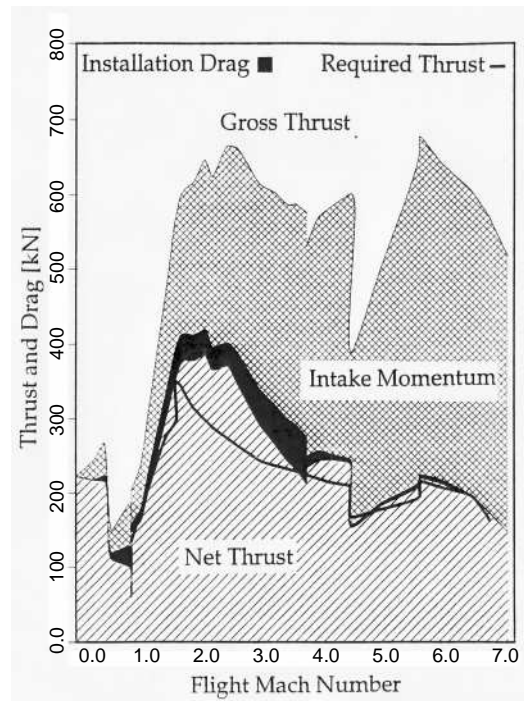

**Fig.28 Gross Thrust – Net Thrust – Required Thrust**

The next figure shows thrust and drag of a turbo-ramjet engine calculated along a typical (e.g. SÄNGER first stage) ascent flight trajectory. From take-off to Mach 0.9 the engine works without afterburner. It is assumed that the turbo-ramjet engine is configured (e.g. "over/under" parallel or "wrapped around" co-axial) that the engine types, ramjet and turbo with max reheat, can both operate simultaneously in parallel. Transition from the turbo to ram takes place at Mach 3.5. The boundary layer is diverted from the intake during turbo operation but not during ramjet operation. This causes a step in thrust at Mach 3.5 mainly due to the reduced pressure recovery and mass flow. In addition a cruise phase is foreseen at Mach 4.5 (Required thrust = net thrust). The critical value thrust minus drag is clearly shown where only a small positive thrust is available for acceleration of the vehicle.

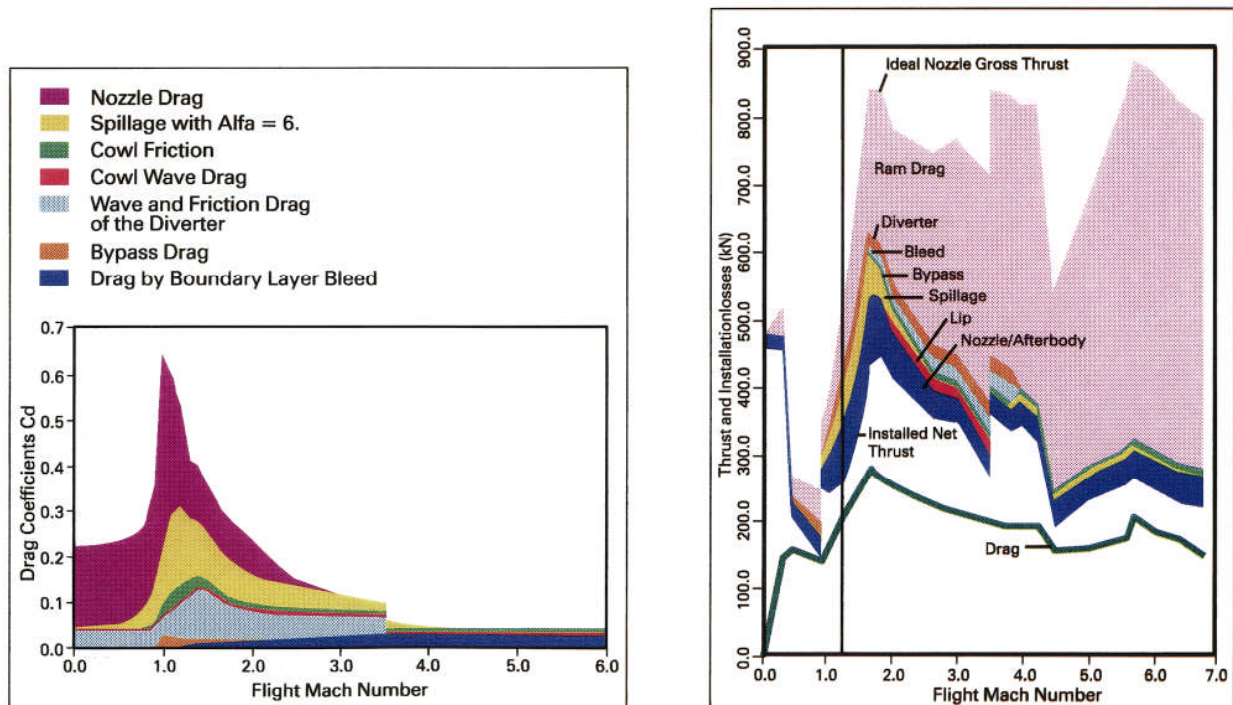

Installation Losses due to Propulsion Integration are of the same Order as Vehicle Drag

Fig. 29 Thrust and Installation Losses for Ascent Trajectory (TSTO-SÄNGER)

A more detailed drag brake-down into its main components is shown in the next figure, left side. At Mach numbers  $\leq 3$  the nozzle drag (the nozzle design point is near  $Mach_{max}$ ), the spillage drag (the engine can ingest only part of the intake flow), and the wave and friction drag of the diverter are the major parts of the engine installation drag with its maximum peak at transonic and low supersonic speed.

The figure on the right side shows the results from the SÄNGER first stage analysis of ideal nozzle gross thrust, installation drag brake-down, the installed net thrust and the overall vehicle drag. Differences with the previous Fig. 25 result from the different turbo-ramjet arrangement which does not allow parallel operation of turbo and ram mode.

**Please note:** Installation losses due to propulsion integration are of the same order as vehicle drag.

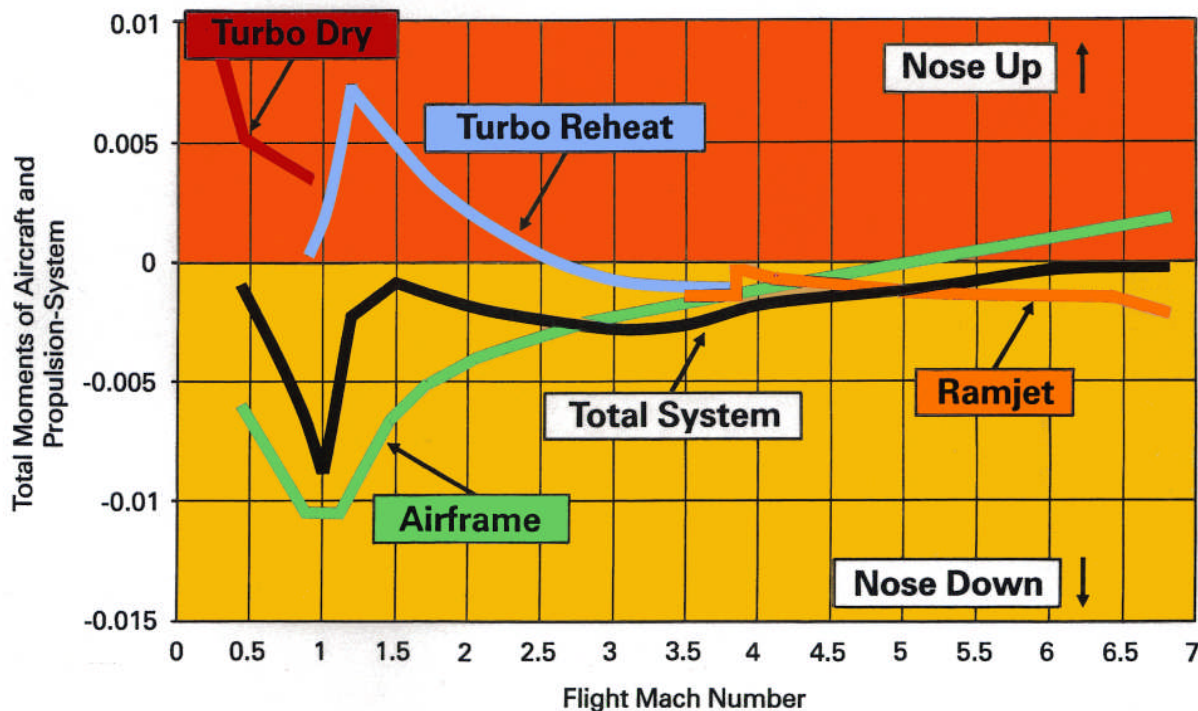

**Influence of Propulsion on Vehicle Stability is Large, therefore Dominating Conceptual Vehicle Designs**

**Fig. 30 Engine/Airframe Integration Design Philosophy wrt A/C Stability & Trim**

In addition to the engine airframe integration effects on drag is its effect on the longitudinal moment of the flight vehicle. Therefore these propulsion system's induced effects have to be optimized together with the aerodynamic flight mechanics and flight performance together with the design of the airframe. It has already been discussed that the forces acting at the intake as well as the nozzle and after-body expansion rate are not in line with the flight direction. Due to the strongly asymmetric design of the intake and nozzle and due to the great distances between the components of the propulsion system and the center of gravity of the vehicle, the resulting moments are in the same order of magnitude as the aerodynamic moments of the aircraft itself. The Fig. shows the impact of the Turbo- and ramjet-effect during operation. During low subsonic, transonic and low supersonic flight the compensation of the nose-up generated pitching moment by aerodynamic controls would result in additional trim-drag. Therefore the design of the shape of the airframe ("Camber") can balance the nose-up moment to some extent. The same process works for supersonic speed in the opposite direction.

## 9.0 EXPERIMENTAL VERIFICATION

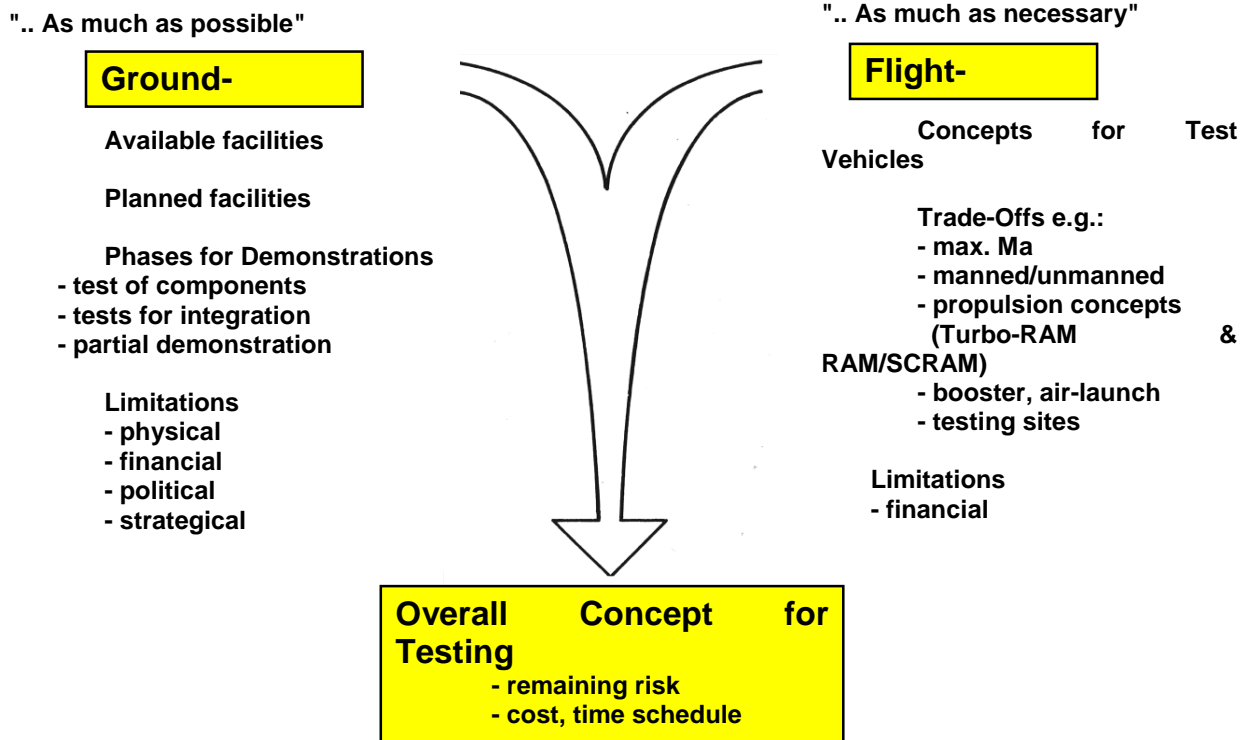

**Fig. 31 Engine/Airframe Integration requires Technology Verification under "Real Flight" Conditions**

The thesis is that engine/airframe integration requires Technology Verification under "Real Flight" conditions. For conventional Aircraft design for subsonic and low supersonic aircraft using experimental windtunnel techniques and numerical CFD codes are quite well established and validated. But this is not the case for hypersonic speed and specifically not for the subject of engine airframe integration. Ground testing "as much as possible" and flight testing "as much as necessary" is the general accepted philosophy.

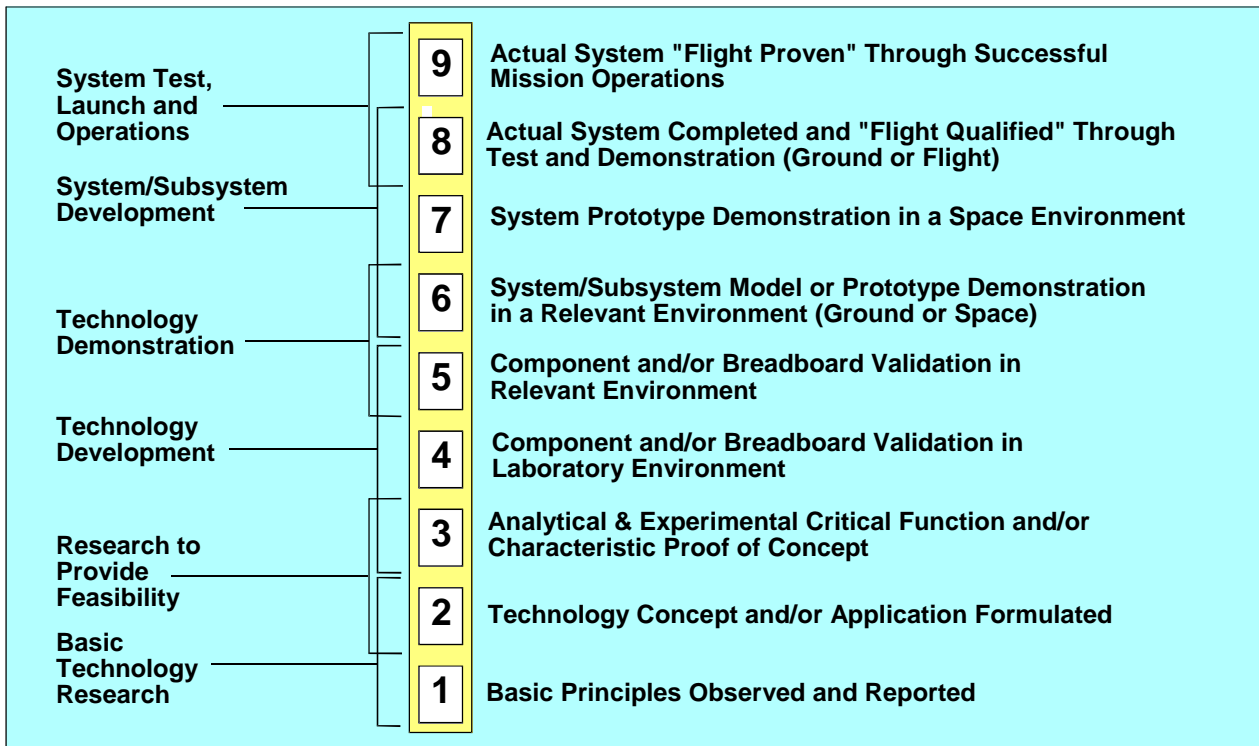

Ref.: Stanley, Piland IAF 93-V.4.627, Oct. 16-22, 1993,

**Fig. 32 NASA: Technology Readiness Level (TRL) - Definition**

A technology Readiness Level 6 according to NASA definition is generally required for the development of a new transport system. For engine aircraft integration and operations that means mandatorily the demonstration by flight testing.



- (1) Proof of RAM-Performance in "Real" Flight Conditions**
- (2) Proof of Operating Air Intake System**
- (3) Proof of Successful Performed Engine/Airframe Integration Concept**
- (4) Validation of Design Tools Applied for Structures and Aerothermodynamics**
- (5) Proof of Hypersonics System Design (e.g. Sensors, Actuators, FCS etc.)**

**These Tasks have to be realized within the Limits of Time and Budget**

**Fig. 33 Objectives for Hypersonic Flight Demonstration  
(Flight Range  $3 < \text{Mach} < 7$  - ?)**

The most important objectives for hypersonic flight demonstration in the speed range of  $3 < \text{Mach} < 7$  are listed.

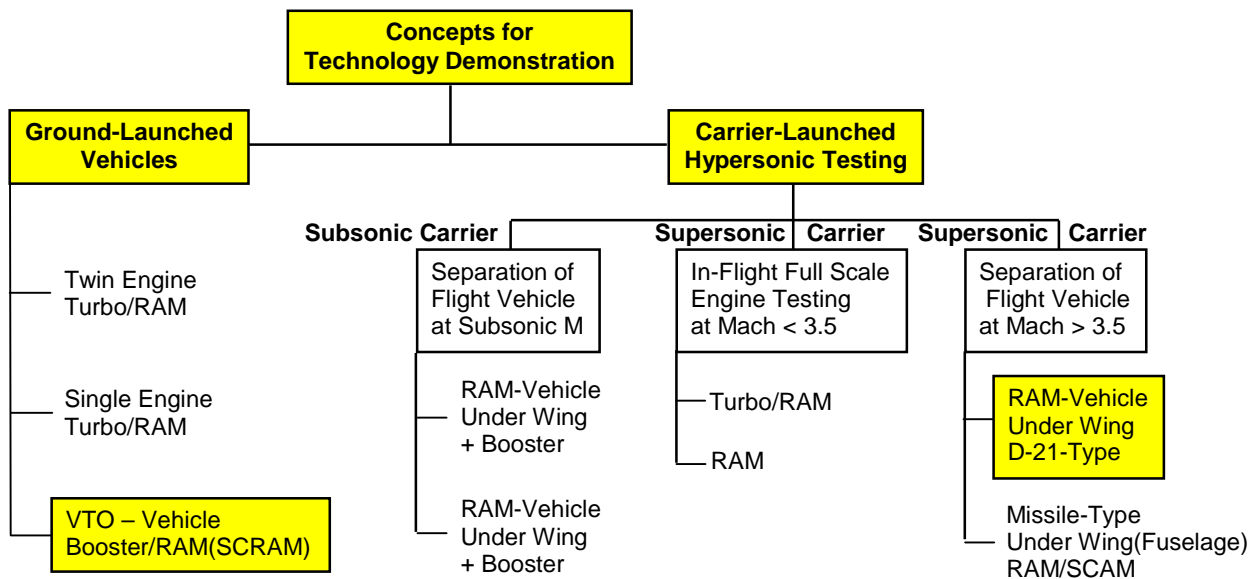

**Fig. 34 Potential RAM(SCRAM)-Jet Demonstrator Concepts for Mach = 6 - 8**

Several proposals for different concepts of potential ram- or scram-jet flight demonstrators have been published worldwide. They can be in principle grouped in two categories: ground launched vehicles and vehicles being launched from an existing carrier (e.g. aircraft, rocket, missile ..). The first group means X-planes (e.g. X-15) which are generally large costly programs. The second group is therefore much attractive concerning an available budget (e.g. X-43a or more recently X-51).

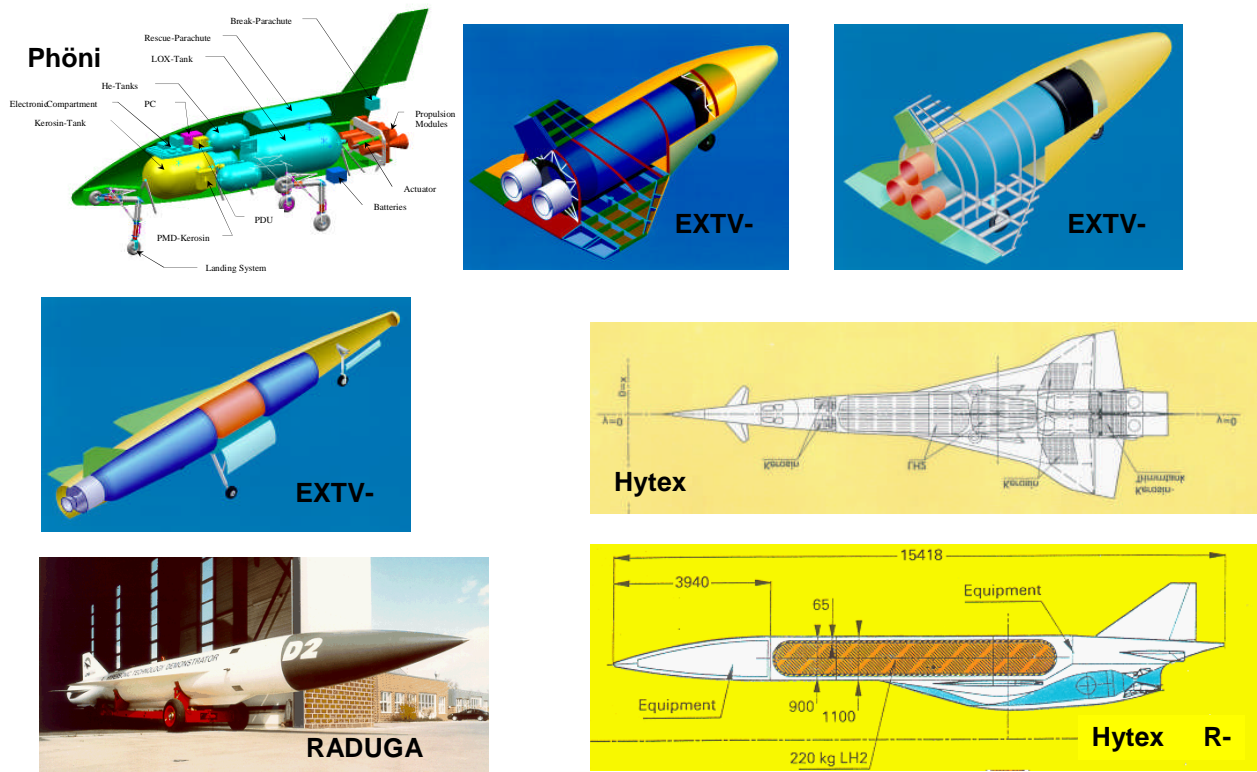

**Fig. 35 Experimental Flying Testbeds fully Integrated for Propulsion Systems During the German HTP and FESTIP (1988 – 1998)**

In Europe several experimental flying testbeds with integrated rocket engines were proposed within the international FESTIP program (EXTVs and Phöni). Concepts for the demonstration of successful in-flight operations were investigated within the hypersonic technology program together with Russian partners (Hytex family and RADUGA D2).

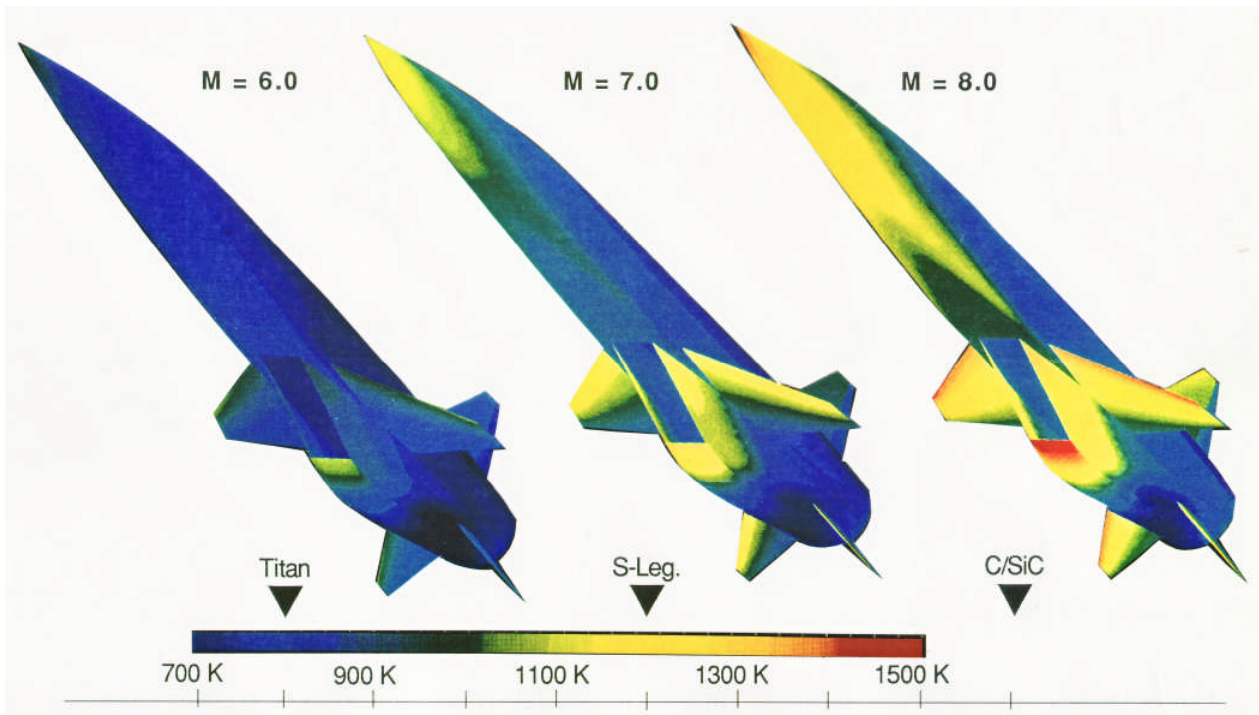

CFD Results for Adiabatic Wall, Emissivity = 0.85, Angle of Attack = 5 deg.

**Fig. 36 Engine/Airframe Integration for Hypersonic Speed Requirements for High-Temperature resistant Materials**

Airbreathing engine airframe integration for hypersonic speed led also to requirements for high temperature resistant materials and structures. In the range of  $6 < \text{Mach} < 8$  "real flight environment" could not be simulated in experimental ground testing facilities with the exception of very short time measurements. Therefore not for propulsion operation using intakes and nozzles. Numerical Methods are available but those methods need also validation by in-flight data acquisition.

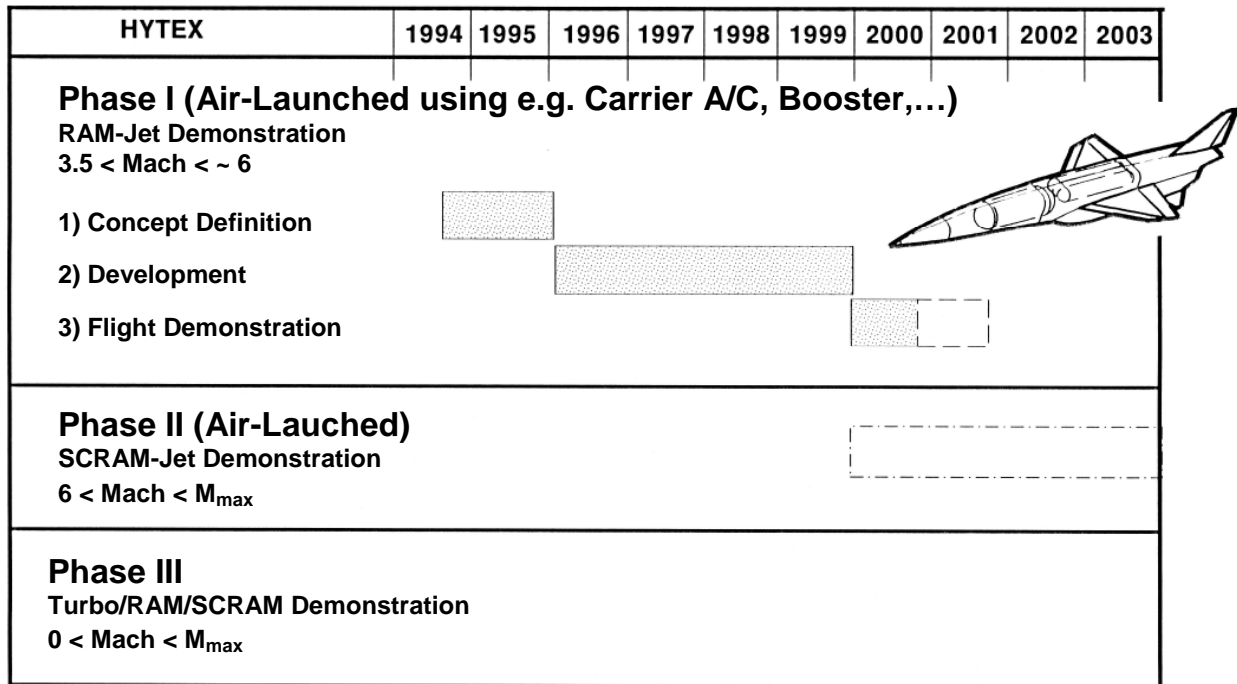
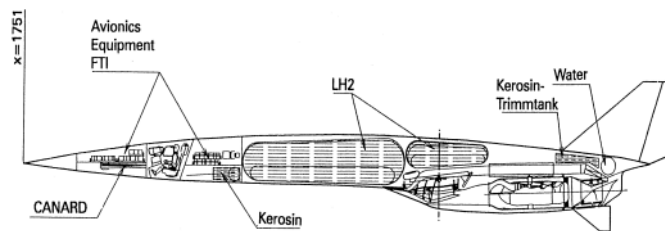

**Fig. 37 Innovative Flight Demonstration of Successful Engine/Airframe Integration and Installed Thrust Performance at Hypersonic Speed**

Within the Hypersonics Technology Program in Germany a proposal was made for an innovative flight demonstration of successful engine/airframe integration and installed thrust performance at hypersonic speed. A stepwise approach should be performed starting with an unmanned air-launched ramjet demonstrator for  $3.5 < \text{Mach} < 6$ . Within one decade also supersonic combustion demonstration should be achieved.

**HYTEX 5.6  
Hypersonic experimental A/C**

- multi cycle engine integration
- real flow aerothermodynamics
- wing/body structural similarity
- manned concept
- HTOL representative system



**Ramjet Engine/Aircraft Integration Demo  
HYTEX R-A<sub>3</sub>**

- hypersonic flight path demonstration
- forebody aerothermodynamics
- reduced structural similarity
- unmanned concept

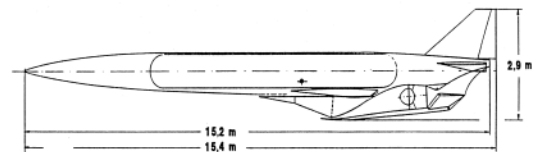

**HYTEX RADUGA Drone D2  
Ram/Scram-In-Flight Operation Demo**

- intake performance and control
- aerothermodynamic database
- hot-structural components tested
- air data sensors
- recovery system
- ram/scram "Passenger" experiment

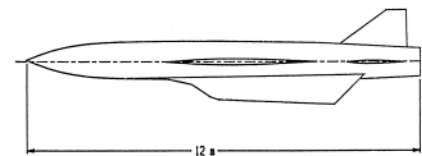
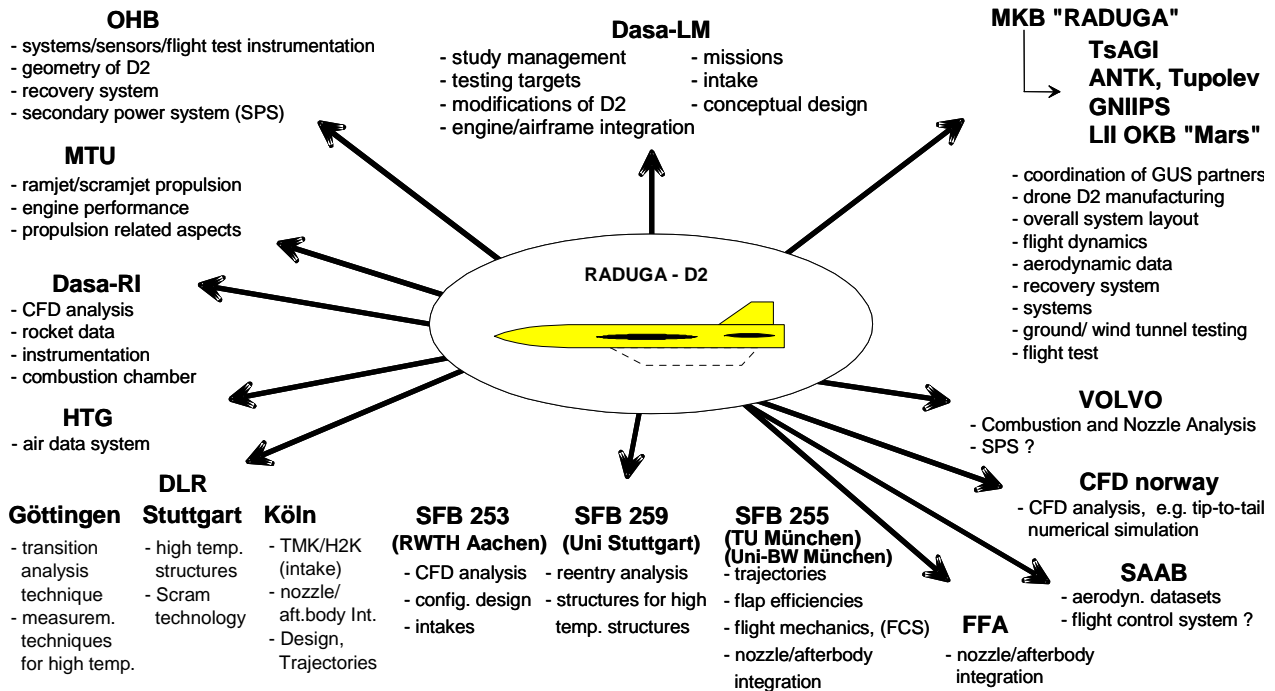

**Fig. 38 From "Experimental A/C" to "Flying Testbed"**

This figure gives a review on several flight testing vehicle concepts investigated in the hypersonic technology program were discussed. Forced by the steadily growing limitation of the budget the way goes from a very comprehensive hypersonic experimental aircraft to a ramjet engine aircraft integration demonstrator and ends finally with an in-flight ram/scram-demonstrator using an existing Russian missile named RADUGA D2 launched from a Russian carrier Aircraft (Tupolev M22). Both engine operation modes had been already tested in Russian windtunnels at TsAGI.

**"Flying Test Bed" RADUGA Drone D2  
Proposed Work-Share**

Status: June 1995



**Fig. 39 "Flying Test Bed" RADUGA Drone D2: Work-Share for International Cooperation**

For the RADUGA D2 flying testbed an agreed work-share of international institutions of industry, research institutes and universities is shown in the next figure. The activities cover all technical disciplines needed for launch, flight demonstration after separation from the carrier aircraft at supersonic speed, data acquisition and transmission to the ground and recovery of the vehicle on ground. It should be mentioned that the German OHB had already received a real hardware of the RADUGA missile D2 from the Russian partners which can be seen in Bremen exposed to visitors. Unfortunately the program was cancelled end 1995. Ten years later a similar experiment has been flown in the US using a Pegasus first stage carrying the X-43A being launched from a B2 which required a Budget one ordered of magnitude higher than the European/Russian approach.

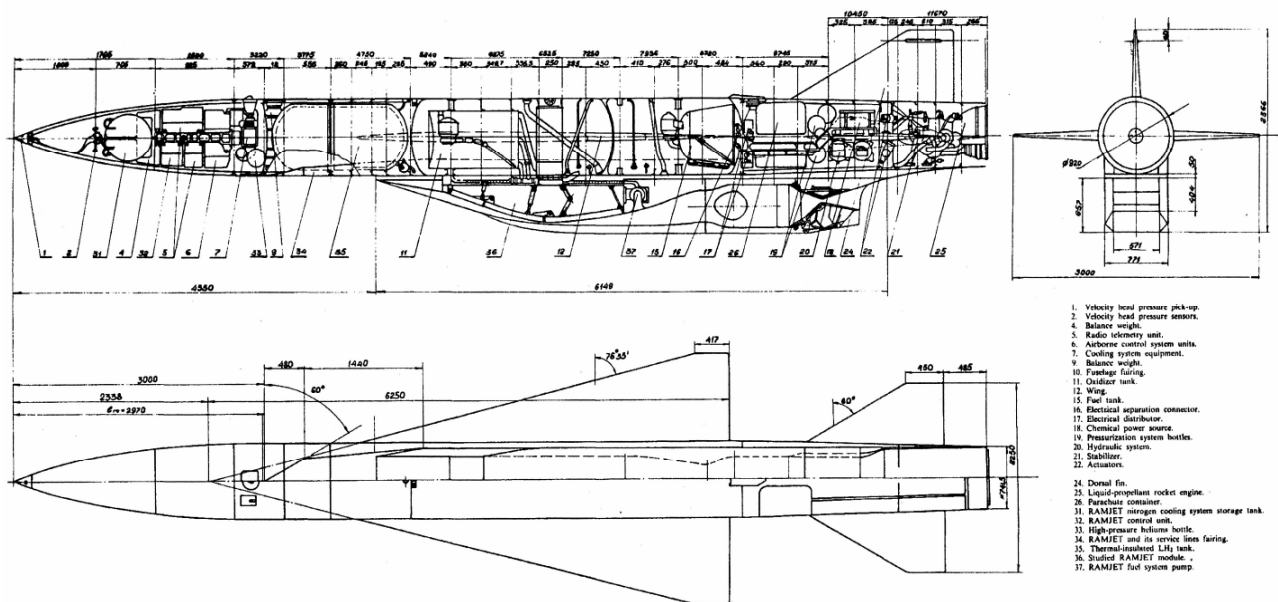

**Fig. 40 RADUGA D2 with Integrated Turbo-Ram Engine for Flight Testing**

Shows how detailed the design of the RADUGA D2 has already been accomplished. The ramjet engine integrated under the fuselage of the Russian missile should have used liquid Hydrogen as fuel for accelerating the missile to a maximum Mach number around 5.6. A speed which had already been flown in Russia in the late 60ties many times using the same structure but propelled by a rocket.



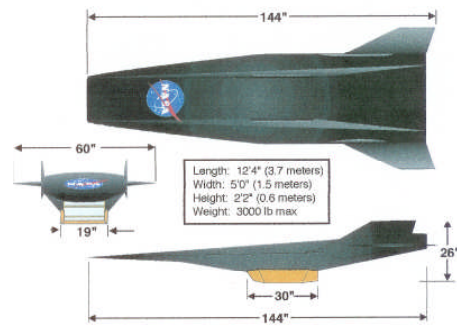
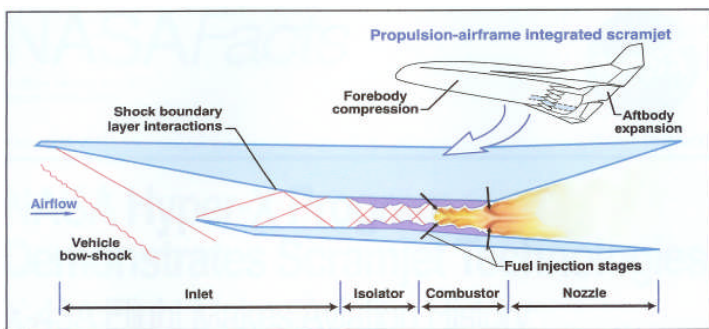

Pictures: Credit

**Fig. 41 Nov. 16, 2004:**  
**NASA's X-43A unmanned research vehicle demonstrated an air-breathing engine can fly at nearly  $M = 10$  at an altitude of approx. 110,000 feet.**

## 10.0 CONCLUSIONS

- Airframe Fore- and Afterbody Design have Large Effect on Propulsion System Performance
- Propulsion System Design (Intake, Nozzle) have Great Influence not only on A/C Performance, but also Trim, Stability, Control
- Propulsion System Design has to be Part of the Overall A/C and Airframe Design Process
- Propulsion Design is no Longer a Selection & Addition of Elements and Components, but Requires Integral Design
- Airframe-Engine Integration for Hypersonic Vehicles Requires Tools, Processes, Skills and People that Communicate and Integrate Airframe & Propulsion Related Knowledge